



Linko Semiconductor Co., Ltd.

# ***LKS32MC05x with built-in 6N driver Datasheet***

© 2020 All rights reserved by Linko Semiconductor  
Confidential. Unauthorized dissemination is prohibited

# 1 Overview

## 1.1 Function

LKS32MC051DC6T8/LKS32MC054DF6Q8/LKS32MC054DOF6Q8 are 32-bit MCU targeting motor control applications. With all modules required for common motor control systems and three-phase NMOS gate driver, it can directly drive three-channel P/N MOS power device. These devices could drive 6 N-Type MOSFET directly. LKS32MC054DOF6Q8 even integrates a 7~20V input 80mA output 5V LDO.

### ● Features

- 96MHz 32-bit Cortex-M0 core
- Low power sleep mode
- Integrated three-phase NMOS gate driver
- Industrial temperature range
- High ESD and group pulse reliability

### ● Memory

- 32kB Flash with optional encryption and 128-bit chip unique identifier
- 2.5K RAM

### ● Operating Conditions

- Dual power supply
- 2.2~5.5V power supply to MCU inside LKS32MC051DC6T8/LKS32MC054DF6Q8, an internal LDO could provide power to digital circuits. Gate drivers could use a 4.5~20V power supply.
- 7~20V power supply to MCU inside LKS32MC054DOF6Q8, an integrated internal 5V LDO could provide power to analog circuits, another LDO for digital circuits. Gate drivers could use a 4.5~20V power supply.
- Operating Temperature: -40~105°C

### ● Clock

- 4MHz built-in high-precision RC clock, with an accuracy of  $\pm 1\%$  at -40~105 °C
- 64KHz built-in low-speed clock for low-power mode
- Internal PLL up to 96 MHz clock

### ● Peripheral Modules

- Two UARTs
- One SPI, support master-slave mode
- One IIC, support master-slave mode
- Two 16-bit timers, support capture and edge-aligned PWM function



- Two 32-bit timers, support capture and edge-aligned PWM function;
- Motor control PWM module, supports 8 channels of PWM output, independent dead-band control
- Hall signal interface with speed measurement and debouncing function
- Hardware watchdog
- 4Groups of 16bit GPIO, P0.0/P0.1/P1.0/P1.1 could be used as wake up source signals. P0[15:0] as external IRQ signals

● **Analog Modules**

- Integrated one 12-bit SAR ADC, 2MSPS sampling and conversion rate, 16 channels in total
- Integrated 2 operational amplifiers, differential PGA mode available
- Integrated two comparators
- Integrated 12-bit DAC digital-to-analog converter
- ± 2 °C built-in temperature sensor
- Built-in 1.2V 0.5% precision voltage reference source
- Built-in one low-power LDO and power monitoring circuit
- Integrated RC clock with high precision and low temperature drift

● **Packaging:**

Table 1-1 Packaging summary Table for LKS32MC05x with Built-in 6N Driver

Device	Package
LKS32MC051DC6T8	TQFP48
LKS32MC054DF6Q8	QFN5*5 40L-0.75
LKS32MC054DOF6Q8	QFN5*5 40L-0.75

**1.2 Main Advantages**

- High reliability, high integration level, small package size, saving BOM cost;
- Integrated 2 channels high-speed OPAs and 2 channels comparators, meeting the different needs of single resistance/double resistance current sampling topology structure;
- High-speed OPA is integrated with over-voltage protection circuit, which allows high-voltage common-mode signals to be directly input, which could support direct current sampling of MOSFET resistance with the simplest circuit topology.
- Via a proprietary technique, ADC and high-speed OPA could cooperate well, making them able to handle a wider current dynamic range, while ensuring the sampling precision of high-speed small current and low-speed high current;
- The control circuit is simple and efficient, with strong anti-interference ability, stable and reliable;
- LKS32MC054DOF6Q8 integrated 5V LDO internally;
- The three-phase N MOS gate driver is integrated;



- Support IEC/UL60730 functional security certification

Applicable to control systems such as inductive BLDC/non-inductive BLDC/inductive FOC/non-inductive FOC and stepper motors, permanent magnet synchronous and asynchronous motors;



### 1.3 Naming Conventions

#### LKS32MC05x Resource Diagram

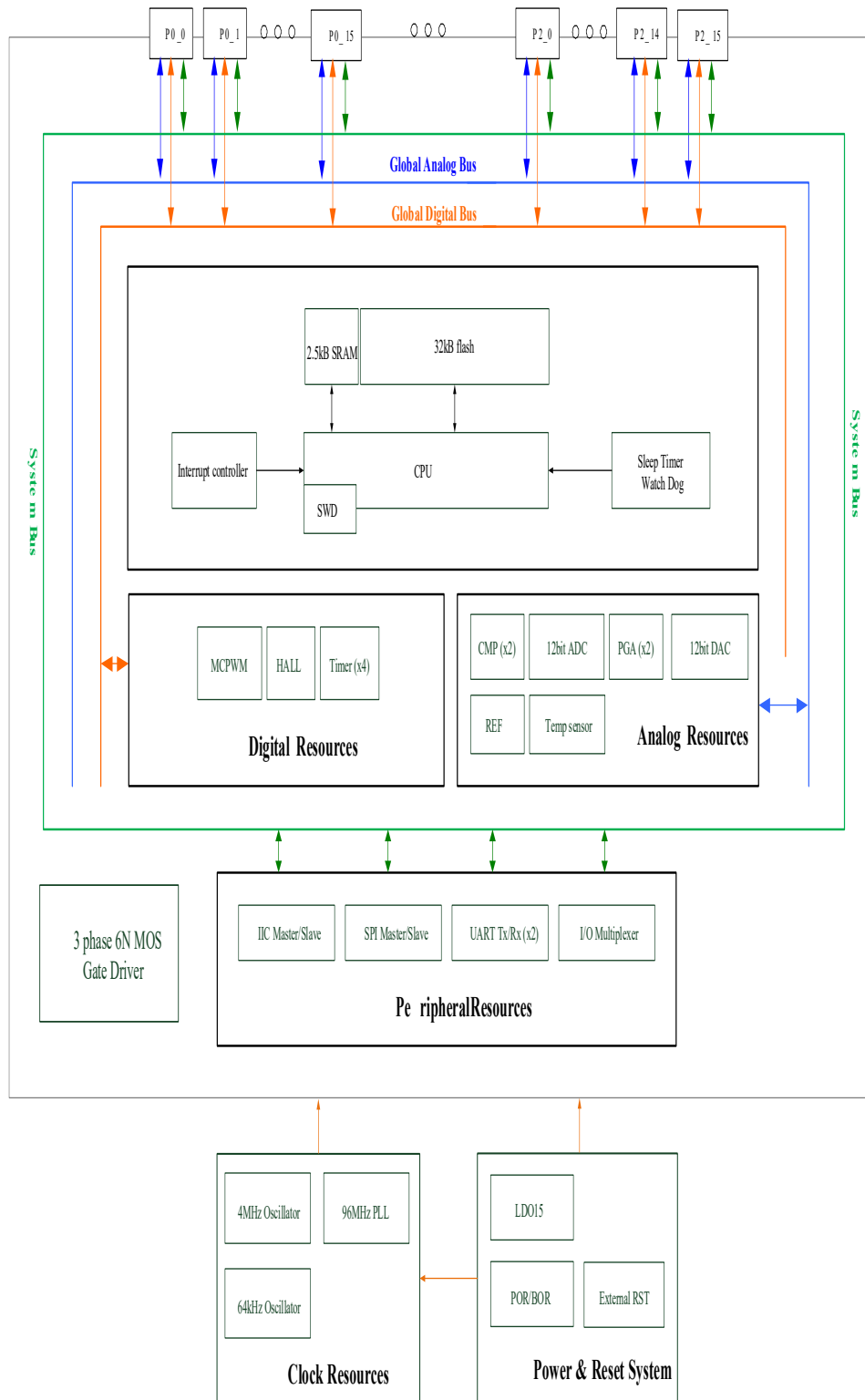

Fig. 1-1 Naming Conventions of LKS32MC05x Components

## 1.4 System Resource

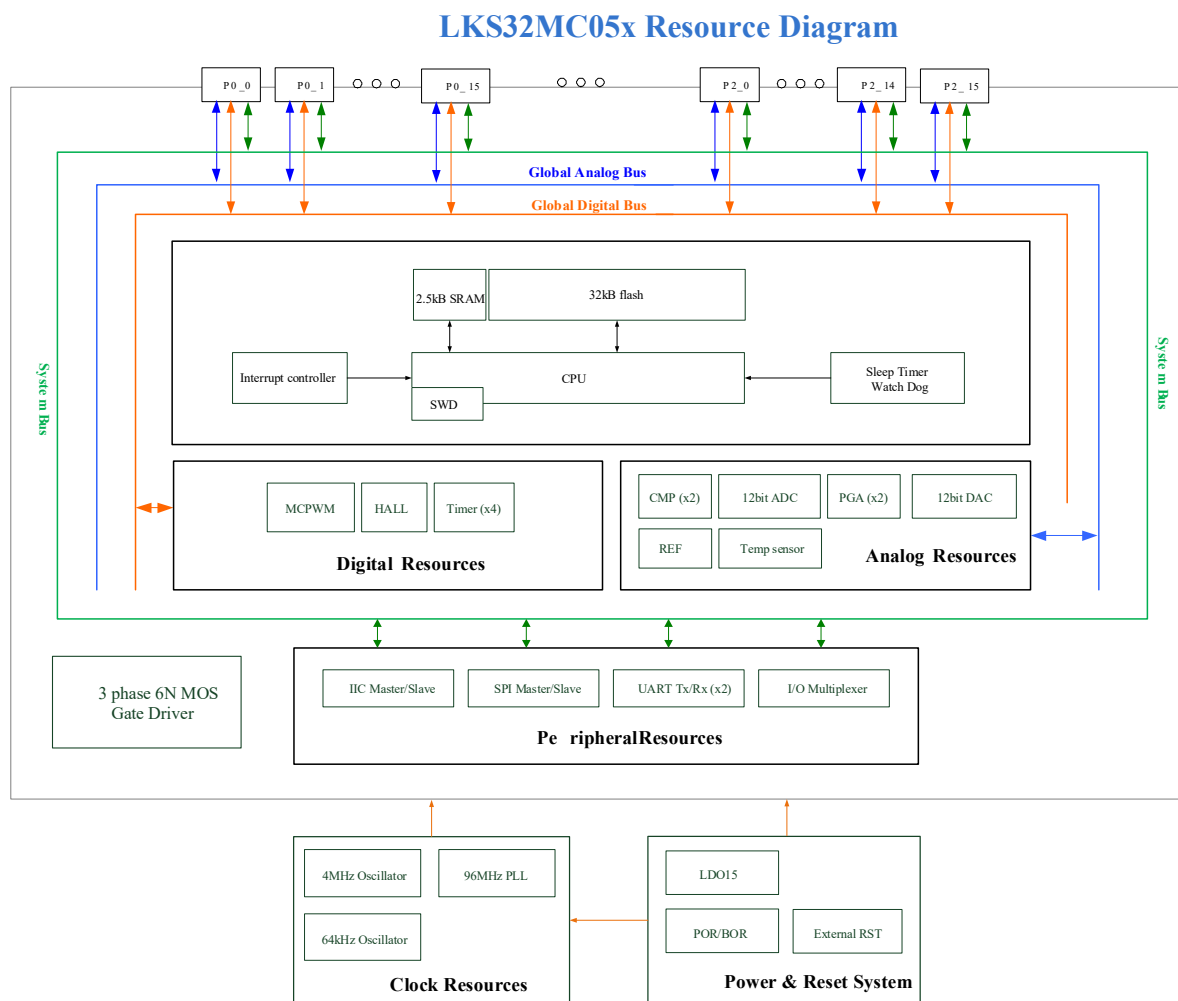

Fig. 1-2 System Block Diagram of LKS32MC05x with Built-in 6N Driver

### 1.5 FOC System Example

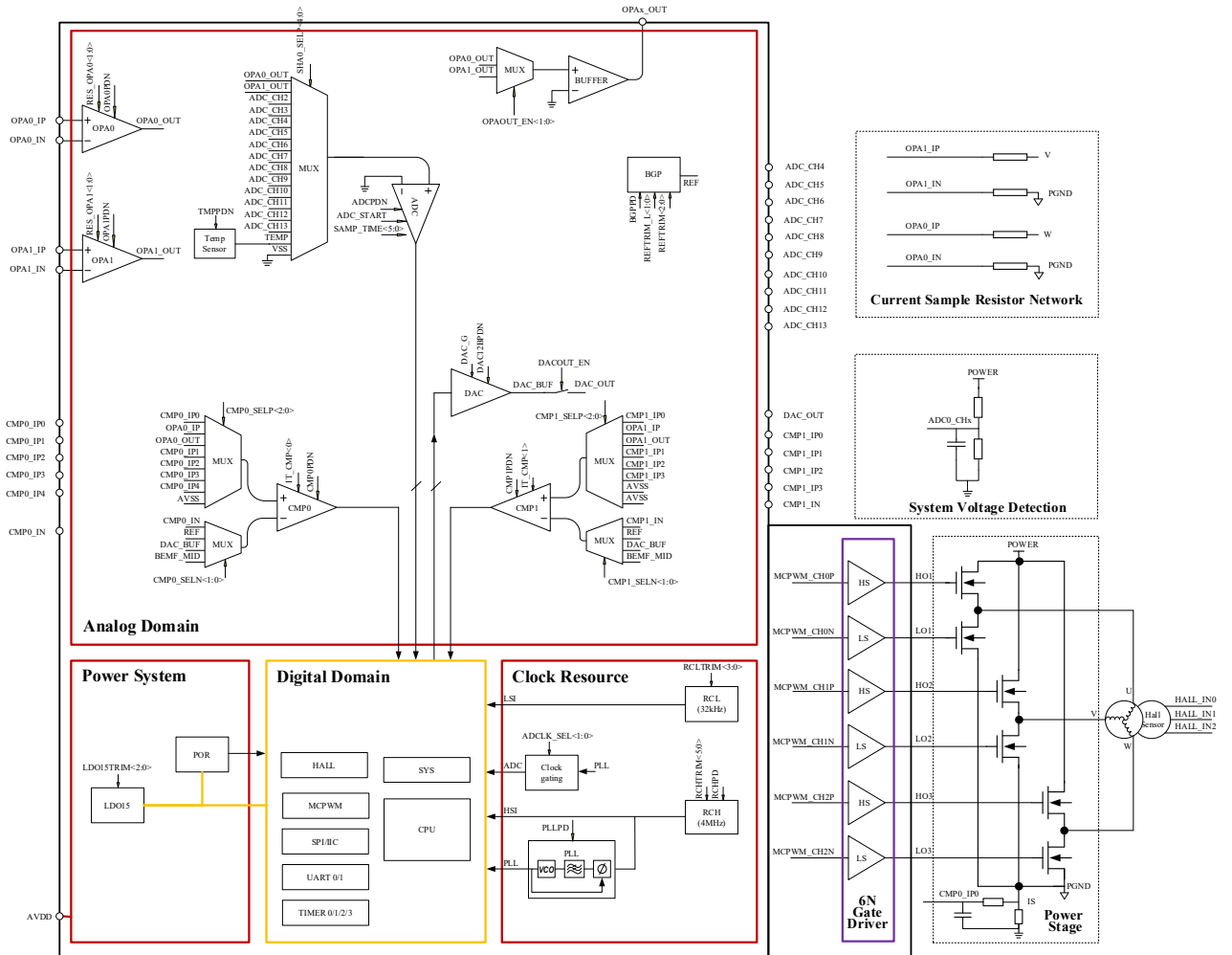

Fig. 1-3 LKS32MC05x with Built-in 6N Driver Simplified Schematic of FOC System

## 2 Device Selection Guide

Table 2-1 LKS05x family device selection guide

	Frequency (MHz)	Flash (kB)	RAM (kB)	ADC ch.	DAC	Comparator	Comparator ch.	OPA <sup>2</sup>	HALL	SPI	IIC	UART	CAN	Temp. Sensor	PLL	QEP	Gate driver	Gate Driver current (A)	Pre-drive supply (V)	Gate floating voltage (V)	Others	Package
LKS32MC051DC6T8	96	32	2.5	11	12BITx1	2	8	2	3路	1	1	2		Yes	Yes		6N	+1.2/-1.5	4.5~20	200		TQFP48
LKS32MC054DF6Q8	96	32	2.5	9	12BITx1	2	8	2	3路	1	1	2		Yes	Yes		6N	+1.2/-1.5	4.5~20	200		QFN5*5 40L-0.75
LKS32MC054DOF6Q8	96	32	2.5	9	12BITx1	2	8	2	3路	1	1	2		Yes	Yes		6N	+1.2/-1.5	4.5~20	200	5V LDO	QFN5*5 40L-0.75



## 3 Pin Assignment

### 3.1 Pin Assignment

#### 3.1.1 Special Notes

The red pin in the pin assignment figures below has built-in pull-up resistors:  
RSTN has a 100k $\Omega$  built-in pull-up resistor, which is enabled automatically after power-up.  
SWDIO/SWCLK has a 10k $\Omega$  built-in pull-up resistor, which is enabled automatically after power-up.  
The remaining red pins have 10k $\Omega$  built-in pull-up resistors, which could be software-enabled.

UART<sub>x</sub>\_TX(RX): UART TX and RX support interchange. When the second function of GPIO is selected as UART, and GPIO\_PIE is input enabled, it can be used as UART\_RX; when GPIO\_POE is enabled, it can be used as UART\_TX. Generally, the same GPIO does not enable input and output at the same time, otherwise the input PDI will receive the data sent by the PDO.

SPI\_DI(DO): The DI and DO of SPI can also be interchanged. When the second function of GPIO is SPI, and GPIO\_PIE is input enable, it can be used as SPI\_DI; when GPIO\_POE is output enable, it can be used as SPI\_DO. Generally, the same GPIO does not enable input and output at the same time, otherwise the input PDI will receive the data sent by the PDO.

3.1.2 LKS32MC051DC6T8

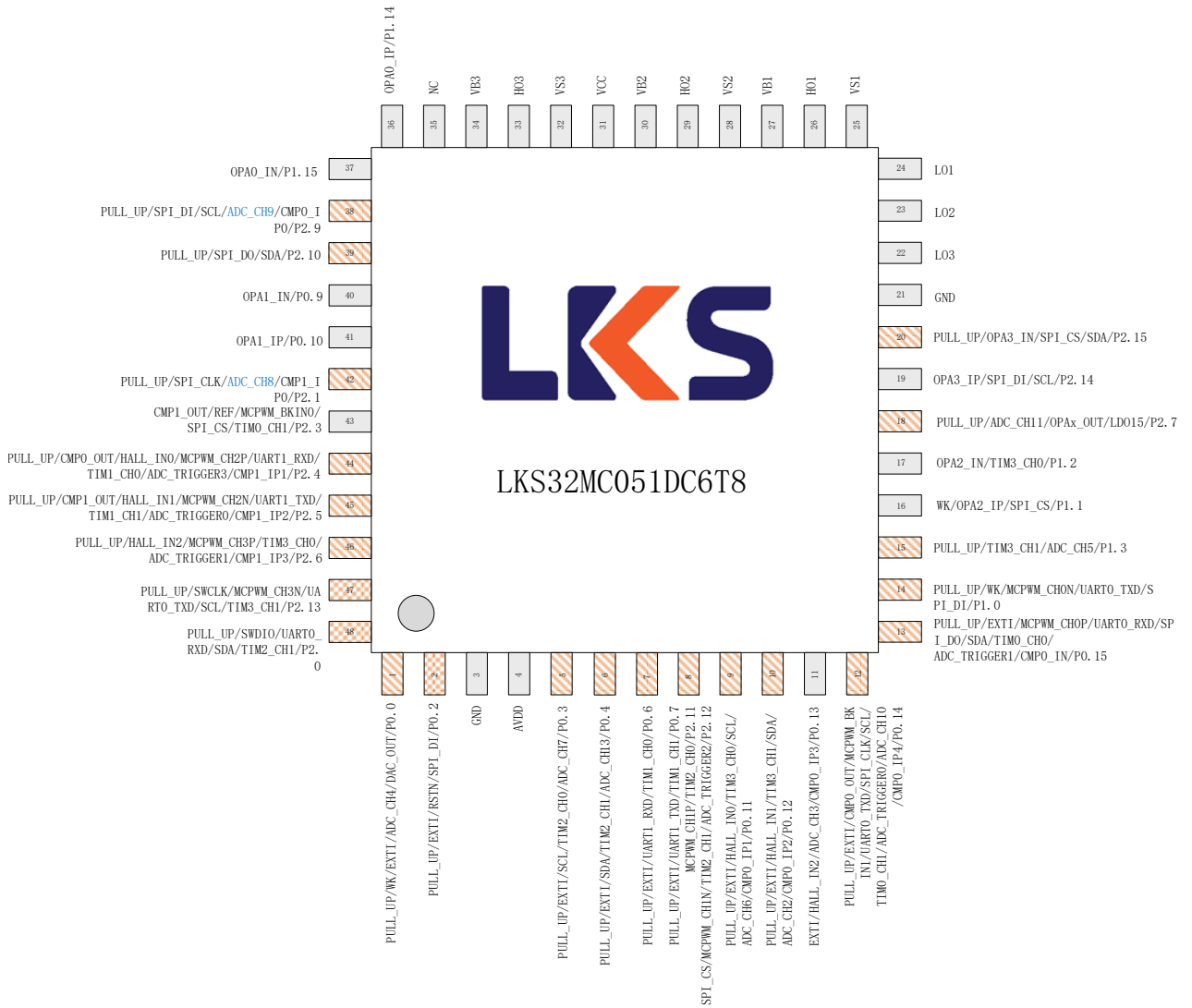

Fig. 3-1 LKS32MC051DC6T8 Pin Assignment

LKS32MC05x with built-in 6N driver Datasheet  
Pin Assignment

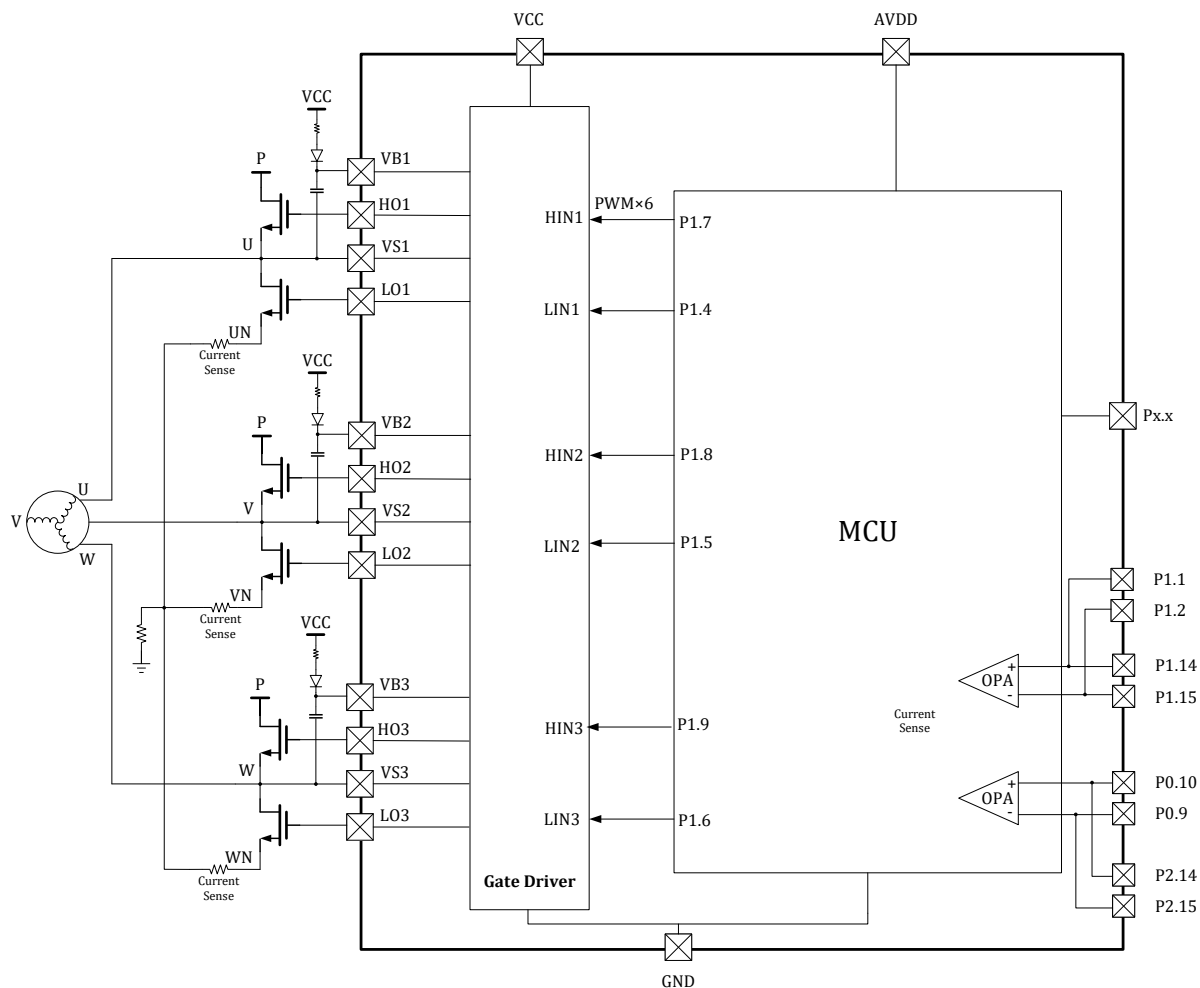

Fig. 3-2 LKS32MC051DC6T8 Schematic diagram of inner driver connection

Caution: Due to internal setting of LKS32MC051DC6T8, ADC\_CH8 and ADC\_CH9 are muxed by OPA2 output and OPA3 output during ADC sampling and conversion. The actual sampling are OPAs' output, not the GPIO input. If you wish to use ADC\_CH8/9 instead, OPA multiplex should be disabled.

LKS32MC05x with built-in 6N driver Datasheet  
Pin Assignment

3.1.3 LKS32MC054DF6Q8

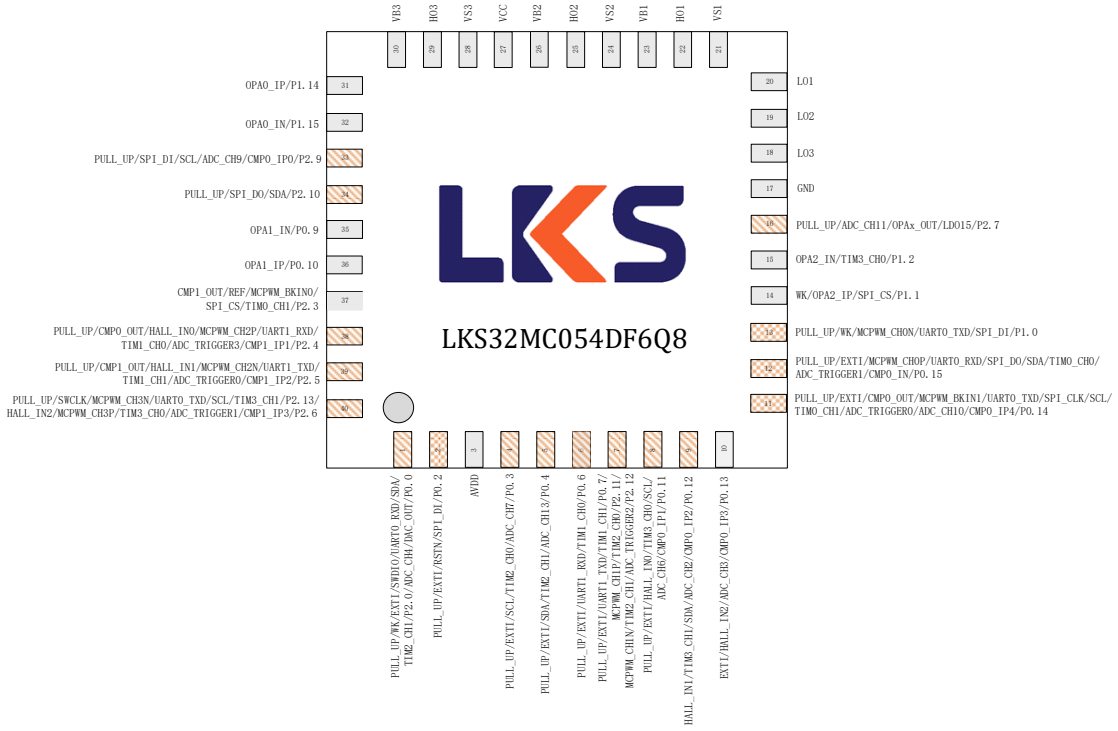

Fig. 3-3 LKS32MC054DF6Q8 Pin Assignment



LKS32MC05x with built-in 6N driver Datasheet  
Pin Assignment

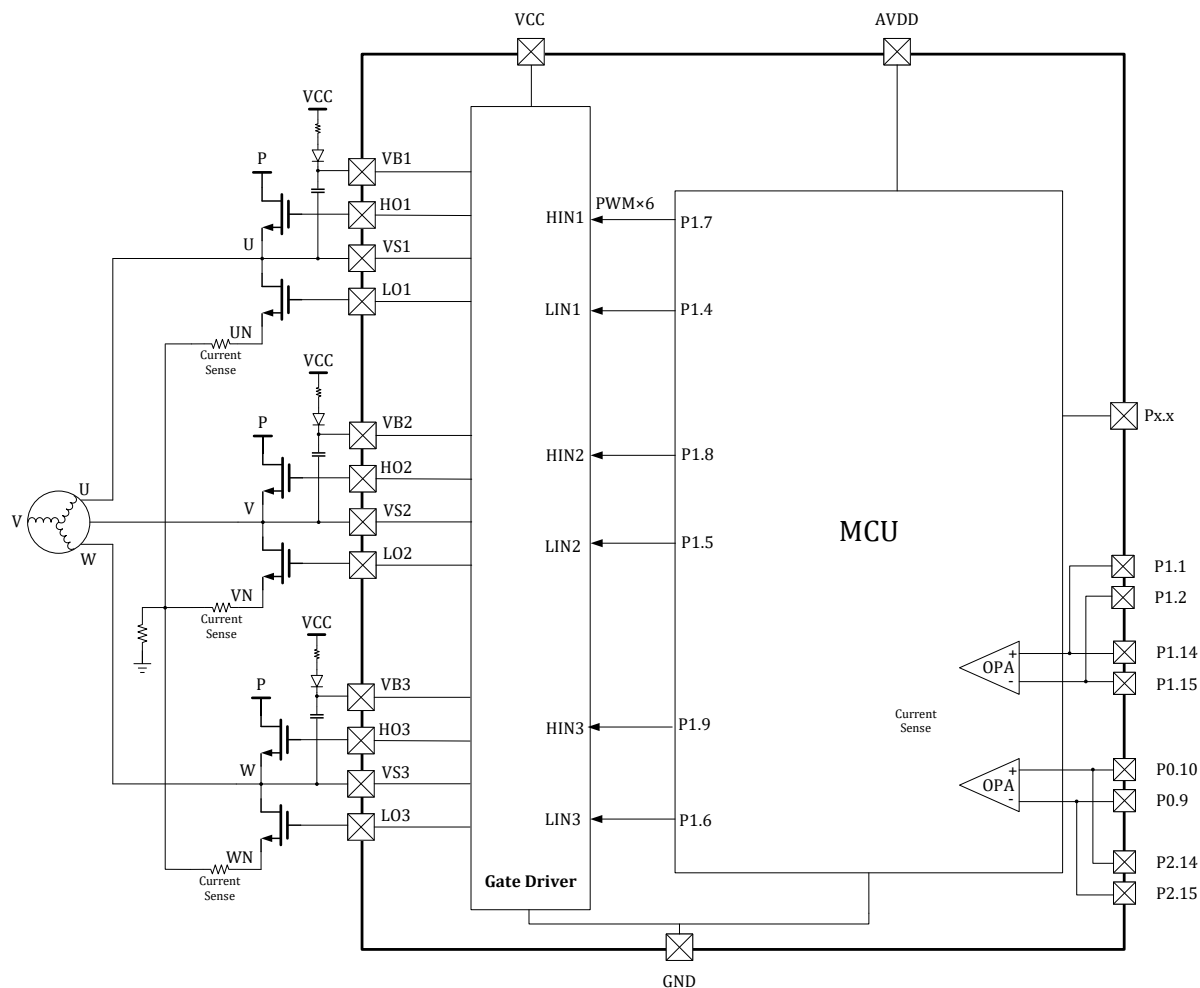

Fig. 3-4 LKS32MC054DF6Q8 Schematic diagram of inner driver connection

Caution: Due to internal setting of LKS32MC054DF6Q8, ADC\_CH8 and ADC\_CH9 are muxed by OPA2 output and OPA3 output during ADC sampling and conversion. The actual sampling are OPAs' output,

LKS32MC05x with built-in 6N driver Datasheet  
Pin Assignment

3.1.4 LKS32MC054DOF6Q8

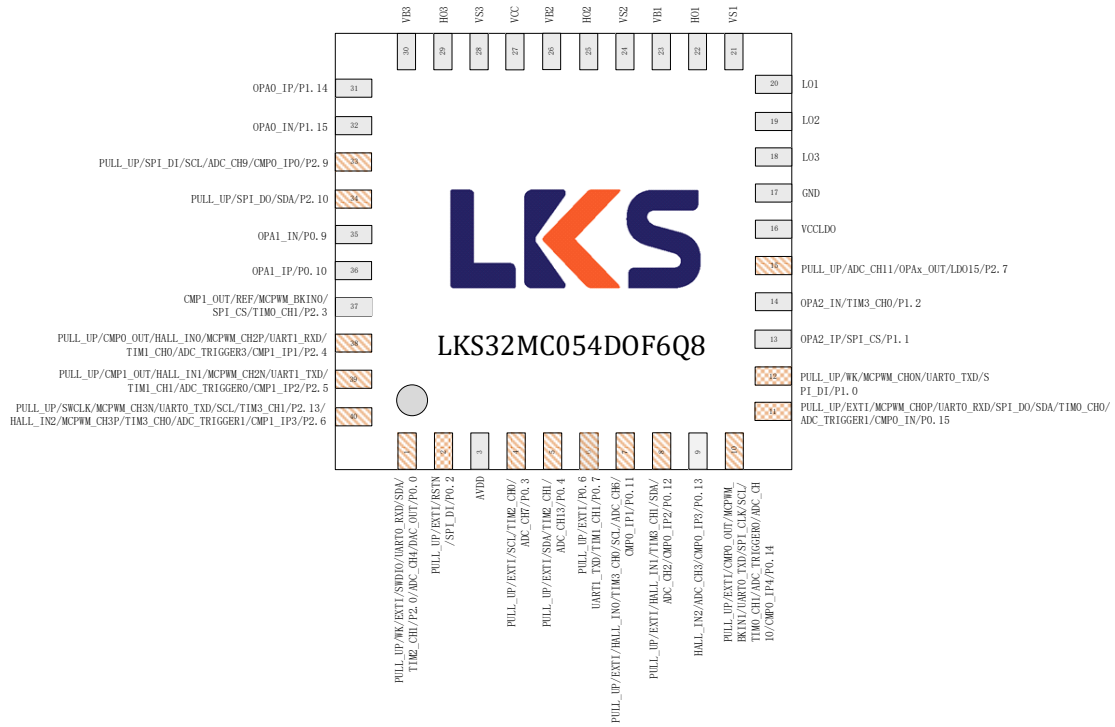

Fig. 3-5 LKS32MC054DOF6Q8 Pin Assignment



LKS32MC05x with built-in 6N driver Datasheet  
Pin Assignment

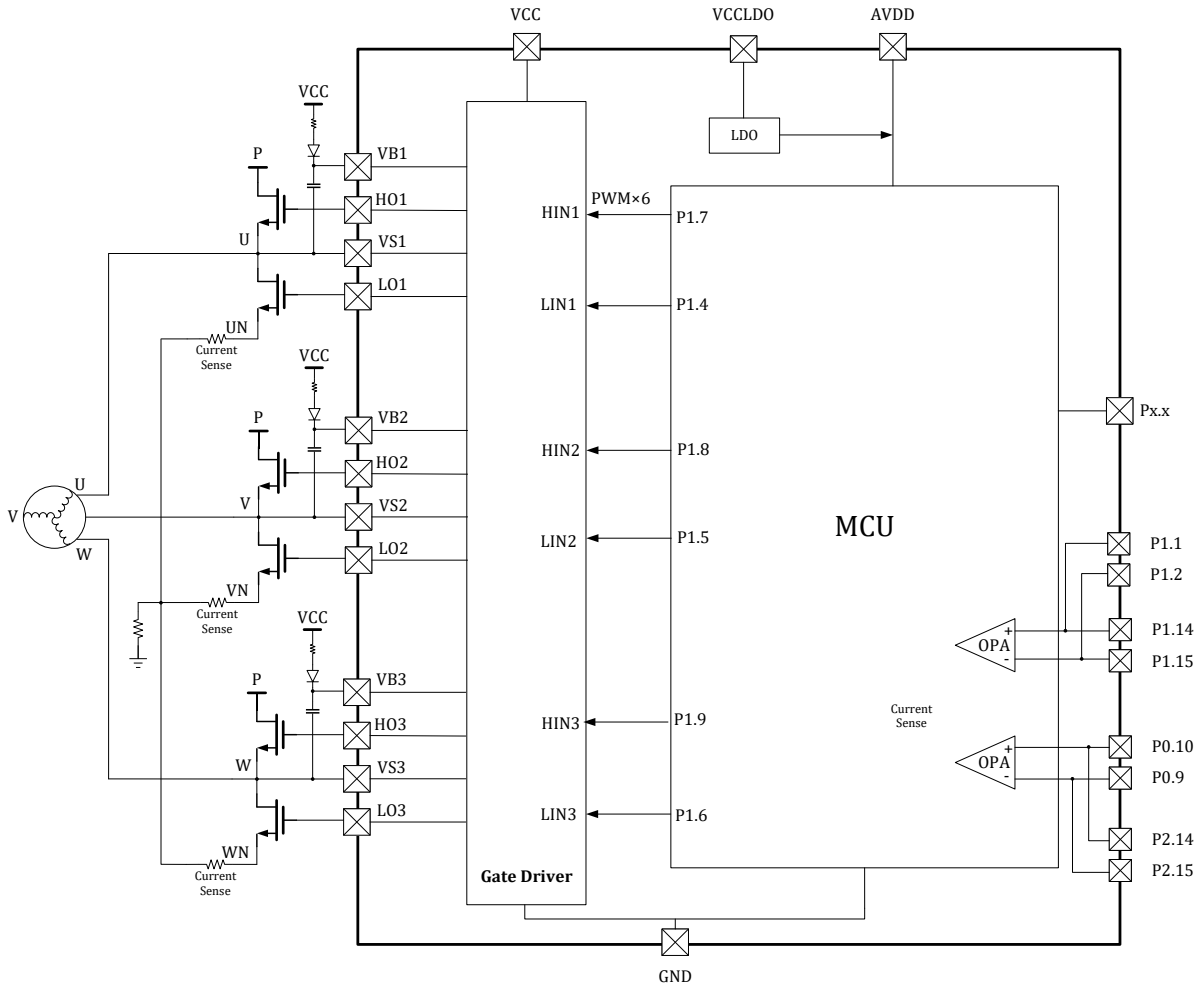

Fig. 3-6 LKS32MC054DOF6Q8 Schematic diagram of inner driver connection

Caution: Due to internal setting of LKS32MC054DOF6Q8, ADC\_CH8 and ADC\_CH9 are muxed by OPA2 output and OPA3 output during ADC sampling and conversion. The actual sampling are OPAs' output,

### 3.2 Pin Function Description

Table 3-1 LKS32MC05x with built-in 6N driver Pin description

051D	054D	054DO	Pin name	Type	Description
	0	0	GND	GND	Ground Pin. It's strongly recommended to connect all the Ground Pin together on PCB.
48	1	1	PULL_UP/SWDIO/UART0_TX(RX)/SDA/TIM2_CH1/P2.0	IO	Pull up/SWD/UART0 TX(RX)/IIC Data/Timer2 Channel1/P2.0, built-in 10k resistor that can be enabled by software
1	1	1	PULL_UP/WK/EXTI/ADC_CH4/DAC_OUT/P0.0	IO	Pull up/Wake up/External interruption/ADC Channel4/DAC Output/P0.0, built-in 10k resistor that can be enabled by software
2	2	2	PULL_UP/EXTI/RSTN/SPI_DI(DO)/	IO	Pull up/External interruption/RSTN/SPI data input(output)/P0.2,



LKS32MC05x with built-in 6N driver Datasheet  
Pin Assignment

051D	054D	054D0	Pin name	Type	Description
			P0.2		used as RSTN by default, a 10nF~100nF capacitor externally connected to the ground, and a 100k pull-up resistor inside. It is recommended to place a 10k-20k pull-up resistor between RSTN and AVDD on the PCB. If there is a pull-up resistor externally, the capacitance of RSTN is fixed to be 100nF.
3			GND	GND	Ground Pin. It's strongly recommended to connect all the Ground Pin together on PCB.
4	3	3	AVDD	PWR	For the 051D/054D product, AVDD is the low-voltage power supply with a power supply range of 2.2~5.5V. A 1uF decoupling capacitor between ground is recommended, and it should be as close as possible to the LDO5V pin. For the 054D0 product, AVDD is the output pin of chip 5V LDO. A 1uF decoupling capacitor between ground is recommended, and it should be as close as possible to the LDO5V pin.
5	4	4	PULL_UP/EXTI/SCL/TIM2_CH0/ ADC_CH7/P0.3	IO	Pull up/External interruption/IIC Clock/Timer2 Channel0/ADC Channel7/P0.3, built-in 10k resistor that can be enabled by software
6	5	5	PULL_UP/EXTI/SDA/TIM2_CH1/ ADC_CH13/P0.4	IO	Pull up/External interruption/IIC Data/Timer2 Channel1/ADC Channel13/P0.4, built-in 10k resistor that can be enabled by software
7	6	6	PULL_UP/EXTI/UART1_TX(RX)/ TIM1_CH0/P0.6	IO	Pull up/External interruption/UART1 TX(RX)/Timer1 Channel0/P0.6, built-in 10k resistor that can be enabled by software
8	7	6	PULL_UP/EXTI/UART1_TX(RX)/ TIM1_CH1/P0.7	IO	Pull up/External interruption/UART1 TX(RX)/Timer1 Channel1/P0.7, built-in 10k resistor that can be enabled by software
8	7		MCPWM_CH1P/TIM2_CH0/P2.11	IO	Motor PWM Channel1 high side/Timer2 Channel0/P2.11
8	7		EXTI/SPI_CS/MCPWM_CH1N/ TIM2_CH1/ADC_TRIG2/P2.12	IO	External interruption/SPI Chip select/Motor PWM Channel1 low side/Timer2 Channel1/ADC trigger signal 2/P2.12
9	8	7	PULL_UP/EXTI/HALL_IN0/SCL/ TIM3_CH0/ADC_CH6/CMP0_IP1/ P0.11	IO	Pull up/External interruption/Hall Sensor A-phase input/IIC clock/Timer3 Channel0/ADC Channel6/ Comparator0 positive input Channel1/P0.11, built-in 10k resistor that can be enabled by software
10	9	8	PULL_UP/EXTI/HALL_IN1/SDA/TI M3_CH1/ADC_CH2/CMP0_IP2/ P0.12	IO	Pull up/External interruption/Hall Sensor B-phase input/IIC data/Timer3 Channel1/ADC Channel2/ Comparator0 positive input Channel2/P0.12, built-in 10k resistor that can be enabled by software
11	10	9	EXTI/HALL_IN2/ADC_CH3/ CMP0_IP3/P0.13	IO	External interruption/Hall Sensor C-phase input/ADC Channel3/Comparator0 positive input Channel3/P0.13
12	11	10	PULL_UP/EXTI/CMP0_OUT/ MCPWM_BKIN1/UART0_TX(RX)/ SPI_CLK/SCL/TIM0_CH1/ADC_TRIG	IO	Pull up/External interruption/Comparator0 Output/Motor PWM brake signal1/UART0 TX(RX)/SPI Clock/IIC clock/Timer0 Channel1/ADC trigger signal 0/ ADC Channel10/ Comparator0



LKS32MC05x with built-in 6N driver Datasheet  
Pin Assignment

051D	054D	054DO	Pin name	Type	Description
			0/ADC_CH10/CMP0_IP4/P0.14		positive input Channel4/P0.14, built-in 10k resistor that can be enabled by software
13	12	11	PULL_UP/EXTI/MCPWM_CH0P/ UART0_TX(RX)/SPI_DO/SDA/ TIM0_CH0/ADC_TRIG1/CMP0_IN/ P0.15	IO	Pull up/External interruption/Motor PWM Channel0 high side/UART0 TX(RX)/SPI data input(output)/IIC data/Timer0 Channel0/ADC trigger signal 1/ Comparator1 negative input / P0.15, built-in 10k resistor that can be enabled by software
14	13	12	PULL_UP/WK/MCPWM_CH0N/ UART0_TX(RX)/SPI_DI(DO)/P1.0	IO	Pull up/Wake up/External interruption/Motor PWM Channel0 low side/UART0 TX(RX)/SPI data input(output)/P1.0, built-in 10k resistor that can be enabled by software
15			PULL_UP/TIM3_CH1/ADC_CH5/ P1.3	IO	Pull up/Timer3 Channel1/ADC Channel5/P1.3, built-in 10k resistor that can be enabled by software
16	14	13	WK/OPA2_IP/SPI_CS/P1.1	IO	Wake up/OPA2 positive input /SPI chip select /P1.1
17	15	14	OPA2_IN/TIM3_CH0/P1.2	IO	OPA2 negative input /Timer3 Channel0/P1.2
18	16	15	PULL_UP/ADC_CH11/OPAx_OUT/ LDO15/P2.7	IO	Pull up/ADC Channel11/OPAx Output/LDO15 Output/P2.7, built-in 10k resistor that can be enabled by software
19			OPA3_IP/SPI_DI(DO)/SCL/P2.14	IO	OPA3 positive input /SPI data input(output) /IIC clock/P2.14
20			PULL_UP/OPA3_IN/SPI_CS/SDA/ P2.15	IO	Pull up/OPA3 negative input /SPI chip select/IIC data/P2.15, built-in 10k resistor that can be enabled by software
		16	VCCLDO	PWR	5V LDO power input, input range 7~20V, maximum output current 80mA. External decoupling capacitor should be >0.33uF and placed as close to PIN VCCLDO as possible
21	17	17	GND	GND	Ground Pin. It's strongly recommended to connect all the Ground Pin together on PCB.
22	18	18	LO3	0	C-phase low side output, controlled by MCU P1.6, The phase of LO3 Output is the same with P1.6, i.e., when P1.6=1, LO3 Output=1. Configuration register MCPWM_SWAP(0x4001_1C7C) should be set to 1
23	19	19	LO2	0	B-phase low side output, controlled by MCU P1.5, The phase of LO2 Output is the same with P1.5, i.e., when P1.5=1, LO2 Output=1. Configuration register MCPWM_SWAP(0x4001_1C7C) should be set to 1
24	20	20	LO1	0	A-phase low side output, controlled by MCU P1.4, The phase of LO1 Output is the same with P1.4, i.e., when P1.4=1, LO1 Output=1. Configuration register MCPWM_SWAP(0x4001_1C7C) should be set to 1
25	21	21	VS1	IO	A-phase high side floating bias voltage
26	22	22	HO1	0	A-phase high side output, controlled by MCU P1.7. The phase of HO3 Output is the same with P1.7, i.e., when P1.7=1, HO1=1



LKS32MC05x with built-in 6N driver Datasheet  
Pin Assignment

051D	054D	054D0	Pin name	Type	Description
27	23	23	VB1	IO	A-phase high side floating power voltage
28	24	24	VS2	IO	B-phase high side floating bias voltage 2
29	25	25	HO2	0	B-phase high side output, controlled by MCU P1.8. The phase of HO1 Output is the same with P1.8, i.e., when P1.7=1, HO2=1
30	26	26	VB2	IO	B-phase high side floating power voltage
31	27	27	VCC	PWR	Full-bridge driver power supply, 4.5~20V
32	28	28	VS3	IO	C-phase high side floating bias voltage
33	29	29	HO3	0	C-phase high side output, controlled by MCU P1.9. The phase of HO1 Output is the same with P1.9, i.e., when P1.7=1, HO1=1
34	30	30	VB3	IO	C-phase high side floating power voltage
35			NC	NC	NC
36	31	31	OPA0_IP/P1.14	IO	OPA0 positive input /P1.14
37	32	32	OPA0_IN/P1.15	IO	OPA0 negative input /P1.15
38	33	33	PULL_UP/SPI_DI(DO)/SCL/ ADC_CH9/CMP0_IP0/P2.9	IO	Pull up/SPI data input(output)/IIC Clock/ADC Channel9/Comparator0 positive input Channel0/P2.9, built-in 10k resistor that can be enabled by software. Due to internal settings, ADC will be sampling OPA3's output when it's configured to sample ADC_CH9
39	34	34	PULL_UP/SPI_DO/SDA/P2.10	IO	Pull up/SPI data input(output)/IIC Data/P2.10, built-in 10k resistor that can be enabled by software
40	35	35	OPA1_IN/P0.9	IO	OPA1 negative input /P0.9
41	36	36	OPA1_IP/P0.10	IO	OPA1 positive input /P0.10
42			PULL_UP/SPI_CLK/ADC_CH8/ CMP1_IP0/P2.1	IO	Pull up/Due to internal settings, ADC will be sampling OPA2's output when it's configured to sample ADC_CH8
43	37	37	CMP1_OUT/REF/MCPWM_BKIN0/ SPI_CS/TIM0_CH1 /P2.3	IO	Comparator1 Output/Voltage reference/ Motor PWM brake signal0/SPI Chip select/ P2.3
44	38	38	PULL_UP/CMP0_OUT/HALL_IN0/M CPWM_CH2P/UART1_TX(RX)/TIM1 _CH0/ADC_TRIG3/CMP1_IP1/P2.4	IO	Pull up/Comparator0 Output/Hall Sensor A-phase input/Motor PWM Channel2 high side/UART1 TX(RX)/Timer1 Channel0/ADC trigger signal 3/Comparator1 positive input Channel1/P2.4, built-in 10k resistor that can be enabled by software
45	39	39	PULL_UP/CMP1_OUT/HALL_IN1/ MCPWM_CH2N/UART1_TX(RX)/ TIM1_CH1/ADC_TRIG0/CMP1_IP2/ P2.5	IO	Pull up/Comparator1 Output/Hall Sensor B-phase input/Motor PWM Channel2 low side/UART1 TX(RX)/Timer1 Channel1/ADC trigger signal 0/Comparator1 positive input Channel2/P2.5, built-in 10k resistor that can be enabled by software
46	40	40	PULL_UP/HALL_IN2/MCPWM_CH3 P/TIM3_CH0/ADC_TRIG1/ CMP1_IP3/P2.6	IO	Pull up/Hall Sensor C-phase input/Motor PWM Channel3 high side /Timer3 Channel0/ADC trigger signal 1/Comparator1 positive input Channel3/P2.6, built-in 10k resistor that can be enabled by software
47	40	40	PULL_UP/SWCLK/MCPWM_CH3N/ UART0_TX(RX)/SCL/TIM3_CH1/	I	Pull up/SWD Clock/Motor PWM Channel3 low side/UART0 TX(RX)/IIC Clock/Timer3 Channel1/P2.13, built-in 10k resistor



LKS32MC05x with built-in 6N driver Datasheet  
Pin Assignment

051D	054D	054D0	Pin name	Type	Description
			P2.13		could NOT be disabled



LKS32MC05x with built-in 6N driver Datasheet  
Pin Assignment

Table 3-2 LKS32MC05x Pin Function Selection

Port	AF1	AF2	AF3	AF4	AF5	AF6	AF7	AF8	AF9	AFE	GPIO
P0.0										ADC_CH4, DAC_OUT	PULL_UP/WK/EXTI
P0.1											WK/EXTI
P0.2					SPI_DI(DO)						PULL_UP/EXTI
P0.3						SCL		TIM2_CH0		ADC_CH7	PULL_UP/EXTI
P0.4						SDA		TIM2_CH1		ADC_CH13	PULL_UP/EXTI
P0.5										ADC_CH12	PULL_UP/EXTI
P0.6				UART1_TX(RX)			TIM1_CH0				PULL_UP/EXTI
P0.7				UART1_TX(RX)			TIM1_CH1				PULL_UP/EXTI
P0.8											EXTI
P0.9										OPA1_IP	
P0.10										OPA1_IN	
P0.11		HALL_IN0				SCL		TIM3_CH0		ADC_CH6/CMP0_IP1	PULL_UP
P0.12		HALL_IN1				SDA		TIM3_CH1		ADC_CH2/CMP0_IP2	PULL_UP
P0.13		HALL_IN2								ADC_CH3/CMP0_IP3	
P0.14	CMP0_OUT		MCPWM_BKIN1	UART0_TX(RX)	SPI_CLK	SCL	TIM0_CH1		ADC_TRIG0	ADC_CH10/CMP0_IP4	PULL_UP/EXTI
P0.15			MCPWM_CHOP	UART0_TX(RX)	SPI_DI(DO)	SDA	TIM0_CH0		ADC_TRIG1	CMP0_IN	PULL_UP/EXTI



LKS32MC05x with built-in 6N driver Datasheet  
Pin Assignment

Port	AF1	AF2	AF3	AF4	AF5	AF6	AF7	AF8	AF9	AFE	GPIO
P1.0			MCPWM_CH0N	UART0_TX(RX)	SPI_DI(DO)						PULL_UP/WK
P1.1					SPI_CS					OPA2_IP	WK
P1.2								TIM3_CH0		OPA2_IN	
P1.3								TIM3_CH1		ADC_CH5	PULL_UP
P1.4	LRC		MCPWM_CH0P								
P1.5	HRC		MCPWM_CH0N								
P1.6			MCPWM_CH1P								
P1.7			MCPWM_CH1N								
P1.8			MCPWM_CH2P								
P1.9			MCPWM_CH2N								
P1.10			MCPWM_CH3P	UART0_TX(RX)		SCL	TIM0_CH0		ADC_TRIG2		
P1.11			MCPWM_CH3N	UART0_TX(RX)		SDA	TIM0_CH1		ADC_TRIG3		
P1.12											
P1.13					SPI_CLK		TIM0_CH0				
P1.14										OPA0_IP	
P1.15										OPA0_IN	



LKS32MC05x with built-in 6N driver Datasheet  
Pin Assignment

Port	AF1	AF2	AF3	AF4	AF5	AF6	AF7	AF8	AF9	AF0	GPIO
P2.0				UART0_TX(RX)		SDA		TIM2_CH1			PULL_UP
P2.1					SPI_CLK					ADC_CH8/CMP1_IP0	PULL_UP
P2.2										CMP1_IN	
P2.3	CMP1_OUT		MCPWM_BKIN0		SPI_CS		TIM0_CH1			REF	
P2.4	CMP0_OUT	HALL_IN0	MCPWM_CH2P	UART1_TX(RX)			TIM1_CH0		ADC_TRIG3	CMP1_IP1	PULL_UP
P2.5	CMP1_OUT	HALL_IN1	MCPWM_CH2N	UART1_TX(RX)			TIM1_CH1		ADC_TRIG0	CMP1_IP2	PULL_UP
P2.6		HALL_IN2	MCPWM_CH3P					TIM3_CH0	ADC_TRIG1	CMP1_IP3	PULL_UP
P2.7										ADC_CH11/OPAx_OUT/LDO15	
P2.8				UART0_TX(RX)	SPI_DI(DO)			TIM2_CH0			
P2.9					SPI_DI(DO)	SCL				ADC_CH9/CMP0_IP0	PULL_UP
P2.10					SPI_DI(DO)	SDA					PULL_UP
P2.11			MCPWM_CH1P					TIM2_CH0			
P2.12			MCPWM_CH1N		SPI_CS			TIM2_CH1	ADC_TRIG2		
P2.13			MCPWM_CH3N	UART0_TX(RX)		SCL		TIM3_CH1			PULL_UP
P2.14					SPI_DI(DO)	SCL				OPA3_IP	
P2.15					SPI_CS	SDA				OPA3_IN	



## 4 Package Size

### 4.1 LKS32MC051DC6T8

TQFP48 Profile Quad Flat Package:

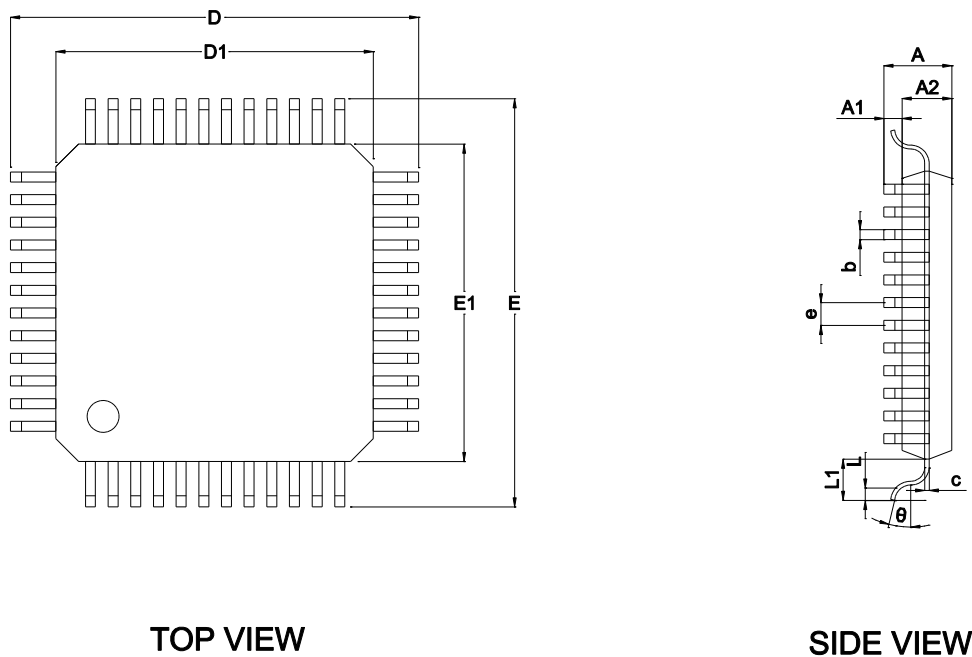

Fig. 4-1 LKS32MC051DC6T8 Package Diagram

Table. 4-1 LKS32MC051DC6T8 Package Dimension

SYMBOL	MILLIMETER		
	MIN	NOM	MAX
A	-	-	1.20
A1	0.05	-	0.15
A2	0.95	1.00	1.05
b	0.18	0.22	0.26
c	0.13	-	0.17
D	8.80	9.00	9.20
D1	6.90	7.00	7.10
E	8.80	9.00	9.20
E1	6.90	7.00	7.10
e	-	0.50	-
$\theta$	0°	3.5°	7°
L	0.45	0.60	0.75
L1	-	1.00	-

## 4.2 LKS32MC054DF6Q8/ LKS32MC054DOF6Q8

QFN5\*5 40L-0.75 Profile Quad Flat Package:

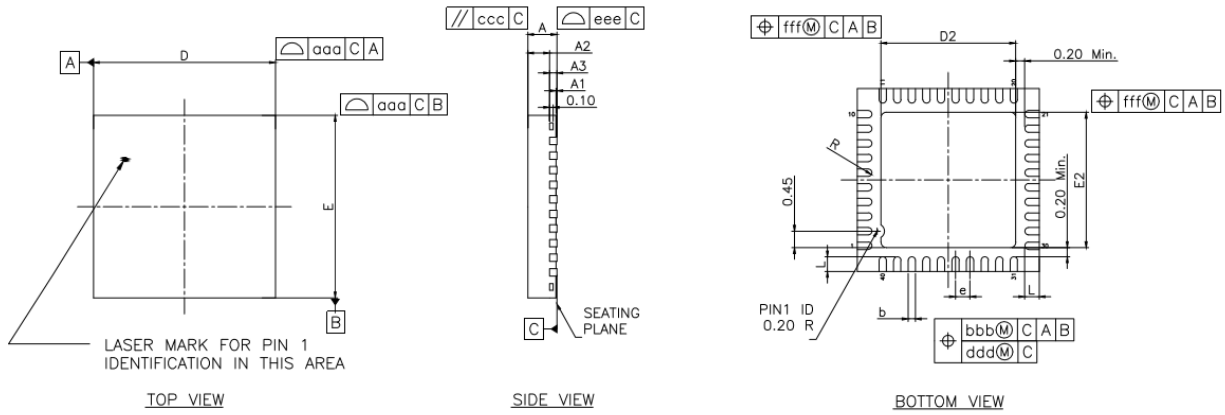

Fig. 4-2 LKS32MC054DF6Q8 Package Diagram

Table. 4-2 LKS32MC054DF6Q8 Package Dimension

SYMBOL	MILLIMETER			INCH		
	MIN.	NOM.	MAX.	MIN.	NOM.	MAX.
A	0.70	0.75	0.80	0.028	0.030	0.032
A1	0.00	0.02	0.05	0.000	0.0008	0.002
A2	0.50	0.55	0.75	0.020	0.022	0.030
A3	0.2 REF			0.008 REF		
b	0.15	0.20	0.25	0.006	0.008	0.010
D	4.90	5.00	5.10	0.193	0.197	0.201
D2	3.20	3.70	3.80	0.126	0.146	0.150
E	4.90	5.00	5.10	0.193	0.197	0.201
E2	3.20	3.70	3.80	0.126	0.146	0.150
L	0.30	0.40	0.50	0.012	0.016	0.020
e	0.4 bsc			0.016 bsc		
R	0.075	-	-	0.003	-	-
TOLERANCE OF FORM AND POSITION						
aaa	0.10			0.004		
bbb	0.07			0.003		
ccc	0.10			0.004		
ddd	0.05			0.002		
eee	0.08			0.003		
fff	0.10			0.004		

## 5 Electrical Characteristics

Table 5-1 LKS32MC05x with Built-in 6N Driver Absolute Maximum Characteristics

Parameter	Min.	Max.	Unit	Description
MCU supply voltage (AVDD)	-0.3	+6.0	V	
Gate Driver supply voltage (VCC)	-0.3	+25.0	V	
LDO supply voltage (VCCLDO)	-0.3	+25.0	V	LDO power supply in 054DO
Operating Temperature	-40	+105	°C	
Storage Temperature	-40	+150	°C	
Junction Temperature	-	125	°C	
Pin Temperature	-	260	°C	Soldering for 10 seconds

Table 5-2 LKS32MC05x with built-in 6N driver Recommended Operating Conditions

Parameter	Min.	Typ.	Max.	Unit	Description
MCU Supply Voltage (AVDD)	2.2	5	5.5	V	
Analog Supply Voltage (AVDD <sub>A</sub> )	2.8	5	5.5	V	
Gate Driver Supply Voltage (VCC)	4.5		20	V	
LDO Supply Voltage (VCCLDO)	7		20		LDO power supply in 054DO

OPA could work under 2.2V, but the output range will be limited.

Table 5-3 LKS32MC05x ESD parameters

Item	Min.	Max.	Unit
ESD test (HBM)	-6000	6000	V

According to "MIL-STD-883J Method 3015.9", under the environment of 25°C and 55% relative humidity, electrostatic discharge is applied to all IO pins of the tested chip for 3 times, with an interval of 1s each time. The test results show that the anti-static discharge level of the chip reaches Class 3A  $\geq 4000V$ ,  $< 8000V$ .

Table 5-4 LKS32MC05x Latch-up parameters

Item	Min.	Max.	Unit
Latch-up current (85°C)	-200	200	mA

According to "JEDEC STANDARD NO.78E NOVEMBER 2016", apply an overvoltage of 8V to all power IOs and inject 200mA of current on each signal IO. The test results show that the anti-latch-up level of the chip is 200mA.

Table 5-5 LKS32MC05x with Built-in 6N Driver IO Absolute Characteristics

Parameter	Description	Min	Max.	Unit
VIN	GPIO signal input voltage range	-0.3	6.0	V
IINJ_PAD	Maximum Injection Current of A Single GPIO	-10	10	mA
IINJ_SUM	Maximum Injection Current of All GPIOs	-50	50	mA



Table 5-6 LKS32MC05x with Built-in 6N Driver IO DC Parameters

Parameter	Description	AVDD	Conditions	Min.	Max.	Unit
V <sub>IH</sub>	High input level of digital IO	5V	-	3.04		V
		3.3V		2.04		
V <sub>IL</sub>	Low input level of digital IO	5V	-		0.3*AVDD	V
		3.3V			0.8	
V <sub>HYS</sub>	Schmidt hysteresis range	5V	-	0.1*AVDD		V
		3.3V				
I <sub>IH</sub>	Digital IO current consumption when input is high	5V	-		1	uA
		3.3V				
I <sub>IL</sub>	Digital IO current consumption when input is low	5V	-	-1		uA
		3.3V				
V <sub>OH</sub>	High output level of digital IO		Current = 11.2mA	AVDD-0.8		V
V <sub>OL</sub>	Low output level of digital IO		Current = 11.2mA		0.5	V
R <sub>pup</sub>	Pull-up resistor*			8	12	kΩ
R <sub>io-ana</sub>	Connection resistance between IO and internal analog circuit			100	200	Ω
C <sub>IN</sub>	Digital IO Input-capacitance	5V	-		10	pF
		3.3V				

\*Only some IOs have built-in pull-up resistors, please refer to section “Pin Function Description” for details.

## 6 Analog Characteristics

Table 6-1 LKS32MC05x with Built-in 6N Driver Analog Characteristics

Parameter	Min	Typ	Max	Unit	Description
<b>ADC</b>					
Power supply	2.8	5	5.5	V	
Sampling rate		3		MHz	$f_{adc}/16$
Differential Input Signal Range	-2.4 +0.048		+2.4 -0.048	V	When Gain=1;REF=2.4V
	-3.6 +0.072		+3.6 -0.072	V	When Gain=2/3;REF=2.4V
Single-ended Input Signal Range	-0.3		AVDD+ 0.3	V	Limited by the input voltage of the IO port
<p>The differential signal is usually the signal output from the OPA inside the chip to the ADC; Single-ended signals are typically sampled externally via an IO input: The ADC should measure the signal amplitude no more than <math>\pm 98\%</math> of the full scale, regardless of the internal/external reference used. In particular, when using an external reference, it is recommended that the sampling conductor not exceed 90% of the scale.</p>					
DC offset		5	10	mV	Correctable
Effective number of bits (ENOB)	10.5	11		bit	
INL		2	3	LSB	
DNL		1	2	LSB	
SNR	63	66		dB	
Input Resistance	500k			Ohm	
Input Capacitance		10pF		F	
<b>Reference Voltage (REF)</b>					
Power supply	2.2	5	5.5	V	
Output Deviation	-9		9	mV	
Power supply rejection ratio(PSRR)		70		dB	
Temperature coefficient		20		ppm/°C	
Output voltage		1.2		V	
<b>DAC</b>					
Power supply	2.2	5	5.5	V	
Load Resistance	50k			Ohm	
Load capacitance			50p	F	
Output voltage range	0.05		AVDD-0 .1	V	
Conversion speed			1M	Hz	
DNL		1	2	LSB	



LKS32MC05x with built-in 6N driver Datasheet  
Analog Characteristics

Parameter	Min	Typ	Max	Unit	Description
INL		2	4	LSB	
OFFSET		5	10	mV	
SNR	57	60	66	dB	
<b>Operational Amplifier (OPA)</b>					
Power supply	3.1	5	5.5	V	
Bandwidth		10M	20M	Hz	
Load Resistance	20k			Ohm	
Load capacitance			5p	F	
Input common-mode range	0		AVDD	V	
Output Common Mode Voltage Range	0.1		AVDD-0.1	V	Under minimum load resistance
OFFSET		10	15	mV	This OFFSET is the equivalent differential input deviation obtained when the OPA differential input is short-circuited and OPA OUT is measured from 0 level. The output deviation of OPA is the OPA magnification $\times$ OFFSET
Common Mode Voltage (V <sub>cm</sub> )	1.65	1.9	2.2	V	Measurement condition: normal temperature. Operational amplifier swing = $2 \times \min(\text{AVDD}-V_{cm}, V_{cm})$ . You are advised to measure the V <sub>cm</sub> and correct software subtraction after powering on applications that use OPA single-end output. For more analysis, please refer to the official website application note ANN009-Differences between OPamp Differential and Single-end Operating Modes.
Common Mode Rejection Ratio (CMRR)		80		dB	
Power Supply Rejection Ratio (PSRR)		80		dB	
Load Current			500	uA	
Slew rate		5		V/us	



Parameter	Min	Typ	Max	Unit	Description
Phase Margin (PM)		60		Deg	
<b>Comparator (CMP)</b>					
Power supply	2.2	5	5.5	V	
Input Signal Range	0		AVDD	V	
OFFSET		-19.2		mV	0 mV hysteresis, CMP output transitions from low to high
		-22.4		mV	0 mV hysteresis, CMP output transitions from high to low
		-18.4		mV	20 mV hysteresis, CMP output transitions from low to high
	-	8.1		mV	20 mV hysteresis, CMP output transitions from high to low
Delay		0.15u		S	Default power consumption
		0.6u		S	Low power consumption
Hysteresis		10		mV	HYS='0'
		0		mV	HYS='1'

Table 6-1 LKS32MC05x 5V LDO Module Parameters

<b>5V LDO</b>					
Input Voltage	7		20	V	
Output Voltage	4.75	5	5.25	V	+/-5% accuracy
Dropout Voltage		2		V	
Output Current		80		mA	
Ripple Suppression		80		dB	
Input Decoupling Capacitance		0.33		uF	Add to VCCLDO pin as described in the pin description section
Output Decoupling Capacitance		1		uF	Add to AVDD pin, see pin description section
Operating Temperature Range	-40		125	°C	

Table 6-2 LKS32MC054DO 5V LDO Module Parameters

<b>5V LDO</b>					
Input Voltage	7		20	V	
Output Voltage	4.75	5	5.25	V	+/-5%accuracy
Dropout Voltage		2		V	
Output Current		80		mA	
Ripple Suppression		80		dB	
Input Decoupling Capacitance		0.33		uF	Add to VCCLDO pin as described in the pin description section



LKS32MC05x with built-in 6N driver Datasheet  
Analog Characteristics

Output Decoupling Capacitance		1		uF	Add to AVDD pin, see pin description section
Operating Temperature Range	-40		125	°C	

Description of Analog Register Table:

Address space of 0x40000040 to 0x40000050 are the calibration registers of each analog module. These registers will be set to a unique calibration value in factory. Generally, users are advised not to configure or change these values. If fine-tuning is required, please read the original settings first, and then adjust based on those values.

Addresses space of 0x40000020 to 0x4000003c are registers open to users. The blank registers must be configured to 0 (these registers will be reset to 0 after power on). Other registers will be configured according to the actual application scenarios.



## 7 Power Management System

### 7.1 AVDD

The power management system is composed of LDO15 module, power detection module (PVD), power-on/power-off reset module (POR).

For 051D/054D, AVDD is the power input, the voltage range is 2.2~5.5V. The off-chip decoupling capacitor is recommended to be  $\geq 1\mu\text{F}$  and as close as possible to the AVDD pin.

For the 054DO, AVDD is a 5V LDO output, and the off-chip decoupling capacitor is recommended to be  $\geq 1\mu\text{F}$  and as close as possible to the AVDD pin.

AVDD is powered by a 2.2V ~ 5.5V supply, and all internal digital circuits and PLL modules are powered by an internal LDO15.

The LDO15 automatically turns on after power-on, without software configuration, and the LDO output voltage can be adjusted through software.

The output voltage of LDO15 can be adjusted by setting register LDO15TRIM <2:0>. The corresponding value of the register can be seen in the analog register table. LDO15 has been calibrated before it leaves the factory. Generally, users do not need to configure these registers again. If fine-tuning of the LDO output voltage is required, please read the original configuration value first, and then add the configuration value corresponding to the fine-tuning amount to the register.

The POR module monitors the voltage of the LDO15. When the voltage of the LDO15 is lower than 1.1V, for example, at the beginning of power-on or at the time of power-off, it will provide a reset signal for the digital circuit to avoid any abnormal operation

### 7.2 VCC

The power supply range of the VCC pin is 4.5~20V, which provides power for the on-chip driver module, and the typical value of the undervoltage protection threshold is 4V.

### 7.3 VCCLDO

The power supply range of the VCCLDO pin in the 054DO model is 7~20V, which provides power for the 5V LDO module in the chip. If 5V AVDD is used for external power supply, the power supply current is limited to below 20mA.



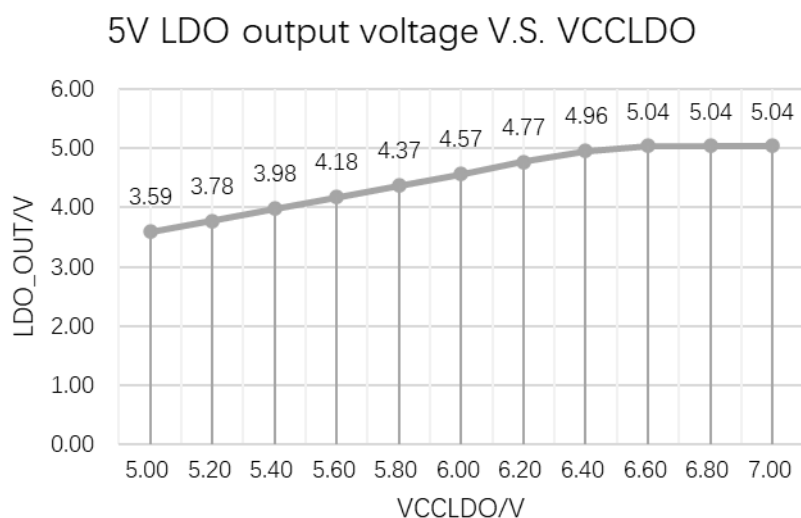

Figure 7-1 5V LDO output V.S. VCCLDO

The 5V LDO module is integrated in 054D0, due to the characteristics of linear power supply, when the input voltage is high (for example,  $\geq 15V$ ) and the load current is large (for example,  $\geq 30mA$ ), the heat generated by the LDO is more obvious. It may cause the chip to trigger thermal protection when the ambient temperature is around 125 degrees or so.

The current consumption of the chip itself in 5V domain is within 20mA. If the power supply current to external devices is greater than 10mA, a shunt resistor between VCC and VCCLDO could be taken into consideration.

The calculation of resistance value may follow the following formula:

$$R \geq 1.5 \cdot (VCC - VCCLDO) / I$$

Among which, I is the total power consumption on the 5V power supply, including the power consumption of the MCU and the power consumption of the 5V peripheral devices (such as HALL).

In the case of using external shunt resistors, a 5.6V voltage regulator tube should be placed on the VCCLDO pin.

## 8 Clock System

The clock system consists of a 64KHz RC oscillator, an internal 4MHz RC oscillator and a PLL.

The 64k RC clock is used in the MCU system as a slow clock for modules such as reset/wakeup source filters or used in the low power mode. The 4MHz RC clock can be used as the main clock of the MCU, and can provide a reference clock to PLL. PLL clock is up to 96MHz.

Both 64k and 4M RC clocks will be through factory calibration, in the range of -40 ~ 105 °C, the accuracy of the 64K RC clock is  $\pm 50\%$ , and the accuracy of the 4M RC clock is  $\pm 1\%$ .

The 4M RC clock is turned on by setting RCHPD = '0' (ON by default, turn off when set to "1"). The RC clock needs a reference voltage and current provided by the Bandgap voltage reference module; thus, do remember to turn on the BGP module before turning on the RC clock. When the chip is powered on, the 4M RC clock and BGP module are both turned on automatically. The 32K RC clock is always on and cannot be turned off.

The PLL multiplies the 4M RC clock to provide a higher frequency clock for modules like MCU and ADC. The highest frequency of MCU and PWM module is 96MHz, and the typical working frequency of ADC module is 48MHz. It can be set to different frequency by the register ADCLKSEL <1:0>.

PLL is turned on by setting PLLPDN = '1' (OFF by default, turn on when set to '1'). Before turning on the PLL module, the BGP (Bandgap) module should be also turned on first. After the PLL is turned on, it needs a settling time of 6us to achieve a stable frequency output. When the chip is powered on, the RCH clock and BGP module are both turned on. PLL is OFF by default and enabled by software.



## 9 Bandgap Voltage Reference

Reference voltage and current are provided for ADC, DAC, RC clock, PLL, temperature sensor, operational amplifier, comparator and FLASH. Before using any of the above modules, the BGP voltage reference should be turned on first.

When the chip is powered on, the BGP module is turned on automatically. The voltage reference is turned on by setting BGPPD = '0'. From OFF to ON, BGP needs about 2us to stabilize. BGP output voltage is about 1.2V, and accuracy is  $\pm 0.8\%$

The voltage reference can be measured by setting REF\_AD\_EN = '1' and via IO P2.3.



## 10 ADC module

The chip integrated a synchronous double-sampling SAR ADC which is shut down by default when the chip is powered up. Before turning on ADC, the BGP module, 4M RC clock and PLL should be turned on first, and the operating frequency of ADC should be selected. In the default configuration, ADC clock is 48MHz, which corresponds to a conversion rate of 3MSPS.

$f_{adc}$  ADC takes 16 ADC clock cycles to complete one conversion, of which 12 are conversion cycles and 4 are sampling cycles. i.e.  $= \frac{\text{Clock Cycle}}{16}$ . When the ADC clock is set to 48MHz, the conversion rate is 3MSPS. The sampling cycle can be set by configuring the SAMP\_TIME register in SYS\_AFE\_REG7. It is required to be set to more than 6 (including 6), i.e., the sampling time of 10 ADC clk or more. The recommended value is 8, which corresponds to the ADC output data rate of 2MHz.

When the ADC is working at a lower frequency, the power consumption can be reduced by setting register CURRIT<1:0>.

ADC could work in different modes: One-time single channel trigger mode, continuous single channel sampling mode, one-time 1 to 16 channels scanning mode, continuous 1 to 16 channels scanning mode. It has a set of 16 independent registers for each analog channel.

The ADC trigger can be MCPWM/Timer trigger signals T0, T1, T2 and T3 happened for the preset number of times, or software trigger event.

The ADC has two gain modes, which are set by GAIN\_SHAx, corresponding to 1x and 2/3 x gain setting. 1x gain corresponds to an input signal range of  $\pm 2.4V$ , and 2/3 gain corresponds to an input signal range of  $\pm 3.6V$ . When measuring the output signal of the OPA, select the specific ADC gain according to the maximum signal that the OPA may output.

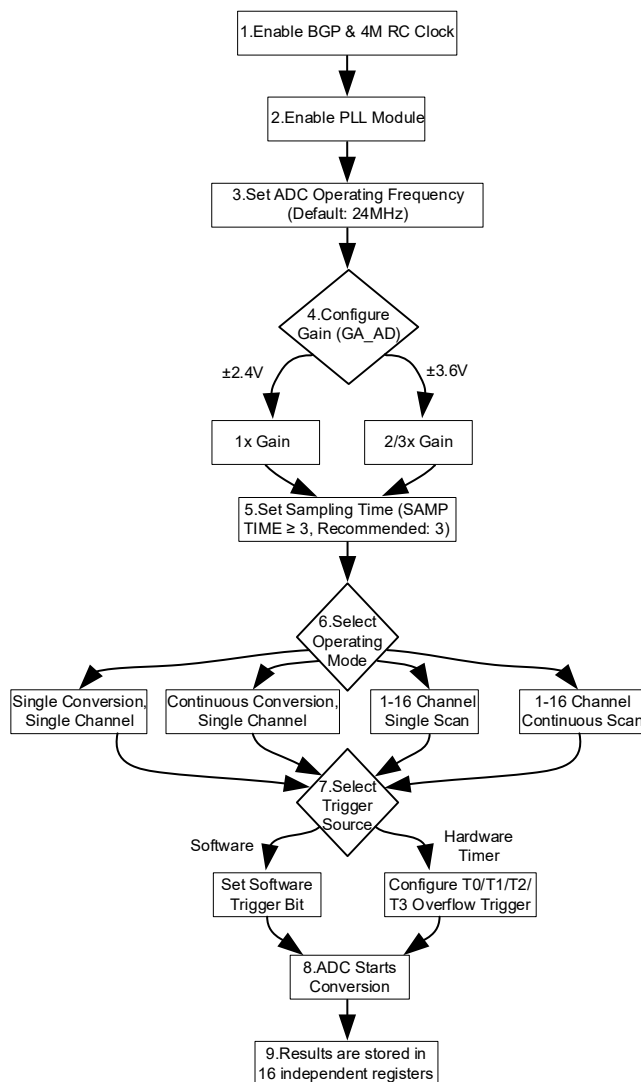

Figure 10-1ADC Configuration Flowchart

## 11 Operational Amplifier

2-channel of rail-to-rail OPAs are integrated, with a built-in feedback resistor  $R2/R1$ . A resistor  $R0$  is required to be connected in series to the external pin. The resistance of feedback resistors  $R2:R1$  can be adjusted by register  $RES\_OPA0<1:0>$  to achieve different gain. For the corresponding value of specific register, please refer to the analog register table.

The close-loop gain of OPA is  $R2/(R1+R0)$ , where  $R0$  is the resistance of the external resistor.

For the application of MOS resistance direct sampling, it is recommended to connect an external resistance of  $>20k\Omega$  to reduce the current flowing into the chip pin when the MOS is turned off;

For the application of small resistance sampling, it is recommended to connect an external resistor of  $100\Omega$ .

The OPA can select one of the output signals of the 2-channels amplifiers by setting  $OPAOUT\_EN<1:0>$ , and send it to the P2.7 IO port through a buffer for measurement. Because of the BUFFER, the operational amplifier is also able to send one output signal in the normal working mode.

When the chip is powered on, the amplifier module is OFF by default. It can be turned on by setting  $OPAxPDN = '1'$ , and turn on the BGP module before turning on the amplifier.

For built-in clamp diodes that are integrated between the positive and negative OPA inputs, the motor phase line could be directly connected to the OPA input through a matching resistor, thereby simplifying the external circuit for MOSFET current sampling.

## 12 Comparator

Built-in 2-channel rail-to-rail comparators with programmable comparator speed, hysteresis voltage, and signal source.

The comparison delay can be set to 0.15 us, and can be set to be less than 30 ns. The hysteresis voltage can be set to 20mV/0mV by CMP\_HYS.

The signal sources of the positive and negative inputs can be programmed by register CMP\_SEL<sub>P</sub><2:0> and CMP\_SEL<sub>N</sub><1:0>. For details, please refer to the analog register description.

When the chip is powered on, the comparator module is OFF. The comparator is turned on by setting CMP<sub>x</sub>PDN = '1', and turn on the BGP module before turning on the comparator.



## 13 Temperature Sensor

The chip has a temperature sensor with an accuracy of  $\pm 2^{\circ}\text{C}$ . The operating temperature of chips will be corrected before leaving the factory, and the corrected value is saved in the flash info area.

When the chip is powered on, the temperature sensor module is OFF. Turn on the BGP module before turning on the temperature sensor.

The temperature sensor is turned on by setting  $\text{TMPPDN} = '1'$ , and it takes about 2us to be stable after turning on. Thus, it should be turned on at least 2us ahead before the ADC measures the sensor output.



## 14 Digital-to-analog Converter (DAC) Module

The chip has a 1-channel 12 bit DAC, and the maximum range of the output signal can be set to 1.2V/4.8V through the register DAC\_G.

The 12bit DAC can be output via IO port P0.0 by setting register DACOUT\_EN = 1, which can drive a load resistance of over 5k $\Omega$  and a load capacitance of 50pF.

The maximum output code rate of the DAC is 1MHz.

When the chip is powered on, the DAC module is OFF. DAC can be turned on by setting DAC12BPDN = 1. Turn on the BGP module before turning on the DAC module.



## 15 Processor Core

- 32-bit Cortex-M0 + DSP dual-core processor
- 2-wire SWD debug pin
- System frequency is up to 96MHz



## 16 Storage

### 16.1 Flash

- Built-in flash including 32kB/64kB main storage area and 1kB NVR
- Available for repeated erasure and writing for at least 20,000 times
- Data retention at room temperature 25°C for up to 100 years
- Single byte program: 7.5us(max), Sector erase: 5ms(max)
- Sector size is 512 bytes. The data can be erased and written according to Sector. It supports runtime programming.
- Flash data anti-theft (any value other than 0xFFFFFFFF must be written to the last word)

### 16.2 SRAM

- Built-in 2.5kB SRAM



## 17 Motor Control PWM

- MCPWM operating frequency is up to 96MHz
- Supports up to 4 channels of complementary PWM output with adjustable phase
- The width of dead-zone in each channel can be configured independently
- Support edge-aligned PWM mode
- Support software control IO mode
- Support IO polarity control
- Internal short circuit protection to avoid short circuit due to configuration error
- External short circuit protection, enabling fast shutdown by monitoring the external signals
- Internal ADC sampling interrupt
- Preload MCPWM register configuration and update simultaneously
- Programmable load time and period



## 18 Timer

- 4-channel standard timer, 2-channel 16-bit timer, 2-channel 32-bit timer.
- Support 4-channel capture mode for measuring external signal/pulse width
- Support 4-channel comparison mode for timed interruption of edge-aligned PWM



## 19 Hall Sensor Interface

- Built-in 1024 cycles filtering at most
- 3-channel Hall signal input
- 24-bit counter, with overflow and capture interrupt



## 20 General Peripherals

- Two UART, full-duplex operation, support 7/8 data bit, 1/2 stop bit, odd/even/no parity mode, with 1 byte tx buffer, 1 byte rx buffer, support Multi-drop Slave/Master mode, support 300 to 115200 baud rate
- One SPI, support master-slave mode
- One IIC, support master-slave mode
- Hardware watchdog, driven by 32kHz RC clock and which is independent of system high-speed clock, the reset time ranges from 0.064s to 32s, the minimum step size is 0.064s.



## 21 Gate driver

### 21.1 Module Parameter

The internal gate driver module of the chip has 3 different parameter specifications. According to the different gate driver circuit parameters, the gate driver module is divided into 3 models, which are G1~G3 respectively. The comparison table is as Table 21-1.

Table 21-1 Device-Gate driver circuit version comparison table

Device	Date Code	Gate Driver
LKS32MC054DF6Q8	YYWWXC	G1
	YYWWX/YYWWXA	G2
	YYWWXB	G3
LKS32MC051DC6T8	YYWWXA	G2
LKS32MC054DOF6Q8	YYWWX	G2

"YYWWX\*" is the data code and chip version number, see the third line of the chip silk print. "YYWWX" is the production date, "\*" is optional, and is usually A, B, C, D... or blank, which represents the version number of the chip pre-driver.

#### 21.1.1 Gate Driver Module G1

Table 21-2 Gate Driver Module G1 parameter

Parameter	Min	Typ	Max	Unit	Description
Absolute Maximum Ratings					
Low side and logic fixed supply VCC	-0.3		+25.0	V	To ground
High side floating supply VB	-0.3		+300	V	
High side offset VS	VB-25		VB+0.3	V	
High side output HO <sub>1,2,3</sub>	VS-0.3		VB+0.3	V	
Low side output LO <sub>1,2,3</sub>	-0.3		VCC+0.3	V	
Logic input HIN/LIN <sub>1,2,3</sub>	-0.3		VCC+0.3	V	Lower of +15V or VCC+0.3
Allowable offset voltage slew rate dVs/dt			50	V/ns	
Package power dissipation Pd			1.6	W	Room temperature 25°
Thermal resistance R <sub>thJA</sub>			83	°C /W	
Junction temperature T <sub>J</sub>			150	°C	
Storage temperature T <sub>s</sub>	-55		150	°C	
Lead temperature			300	°C	Soldering for 10s



Recommended Operating Conditions					
Low side and logic fixed supply VCC	+4.5		+20	V	To ground
High side floating supply VB	VS+4.5		VS+20	V	
High side offset VS	0		260	V	
High side output HO <sub>1,2,3</sub>	VS		VB	V	
Low side output LO <sub>1,2,3</sub>	0		VCC	V	
Logic input HIN/LIN <sub>1,2,3</sub>	0		5	V	
Ambient temperature T <sub>A</sub>	-40		105	°C	
Gate driver Electrical Characteristic					
VCC supply under-voltage trigger voltage	2.9	4.2	5.5	V	
Quiescent VCC supply current	210	330	450	uA	Vin = 0V or 5V
Quiescent VBS supply current	25	45	65		Vin = 0V or 5V
High side bias leakage current	—	—	10	uA	VB = VS = 260V
High side output HIGH short-circuit pulse current	1200	1500	—	mA	VO = 0V, VIN = VIH PW 10 us
High side output LOW short-circuit pulse current	1200	1500	—		VO = 15V, VIN = VIL PW 10 us
Turn-on propagation delay T <sub>on</sub>	—	220	260	ns	VS = 0V
Turn-off propagation delay T <sub>off</sub>	—	110	140		VS = 0V
Turn-on rise time T <sub>r</sub>	—	37	—		C <sub>L</sub> = 1nF
Turn-off fall time T <sub>f</sub>	—	30	—		
Dead time D <sub>T</sub>	—	100	—		
Delay matching M <sub>T</sub>	—	—	50		

### 21.1.2 Gate Driver Module G2

Table 21-3 Gate Driver Module G2 parameter

Parameter	Min	Typ	Max	Unit	Description
Absolute Maximum Ratings					
Low side and logic fixed supply VCC	-0.3		+25.0	V	To ground
High side floating supply VB	-0.3		+250	V	
High side offset VS	VB-25		VB+0.3	V	
High side output HO <sub>1,2,3</sub>	VS-0.3		VB+0.3	V	



Low side output LO <sub>1,2,3</sub>	-0.3		VCC+0.3	V	
Logic input HIN/LIN <sub>1,2,3</sub>	-0.3		VCC+0.3	V	
Allowable offset voltage slew rate dVs/dt			50	V/ns	
Junction temperature T <sub>J</sub>	-40		150	°C	
Storage temperature T <sub>s</sub>	-55		150	°C	
Lead temperature			300	°C	Soldering for 10s
Recommended Operating Conditions					
Low side and logic fixed supply VCC	+8		+20.0	V	相对于地
High side floating supply VB	VS+8		VS+20	V	
High side offset VS	-5		200	V	
High side output HO <sub>1,2,3</sub>	VS		VB	V	
Low side output LO <sub>1,2,3</sub>	0		VCC	V	
Logic input HIN/LIN <sub>1,2,3</sub>	0		VCC	V	
Ambient temperature T <sub>A</sub>	-40		105	°C	
Gate driver Electrical Characteristic					
Quiescent VCC supply current		50	100	uA	HIN=LIN=0V
Quiescent VBS supply current		20	40	uA	HIN=LIN=0V
Floating supply leakage I <sub>LK</sub>			10	uA	VB=VS=220V
VCC supply under-voltage trigger voltage	4.0	4.7	6.7	V	
VBS supply under-voltage trigger voltage	3.9	5.6	6.9	V	
VCC supply under-voltage lock -on voltage	3.6	4.4	6.4	V	
VBS supply under-voltage lock -on voltage	3.5	5.0	6.2	V	
VCC supply under-voltage hysteresis voltage	0.25	0.3	0.8	V	
VBS supply under-voltage hysteresis voltage	0.25	0.6	0.8	V	
High level input threshold voltage V <sub>IH</sub>	2.8			V	
Low level input threshold voltage V <sub>IL</sub>			0.8	V	
Input bias current I <sub>source</sub>		50	120	uA	HIN=LIN=5V
Input bias current I <sub>sink</sub>			1	uA	HIN=LIN=0V
High level output, V <sub>BIAS</sub> -V <sub>O</sub>			1	V	I <sub>O</sub> =20mA
Low level output, V <sub>O</sub>			1	V	I <sub>O</sub> =20mA



High level output short current $I_{O+}$	650	1000		mA	$V_{CC}/V_{BS}=15V$
Low level output short current $I_{O-}$	650	1000		mA	$V_{CC}/V_{BS}=15V$
Turn-on propagation delay $T_{on}$		270	500	ns	
Turn-off propagation delay $T_{off}$		80	150	ns	
Turn-on rise time $T_r$		15	30	ns	$C_L=1nF$
Turn-off fall time $T_f$		12	30	ns	
Dead time $D_T$	100	200	400	ns	
Delay matching $M_T$			80	ns	$T_{on}$ & $T_{off}$ for (HS-LS)

### 21.1.3 Gate Driver Module G3

**A bootstrap diode is integrated in the pre-driver.**

Table 21-4 Gate Driver Module G3 parameter

Parameter	Min	Typ	Max	Unit	Description
Absolute Maximum Ratings					
Low side and logic fixed supply VCC	-0.3		+25.0	V	To ground
High side floating supply VB	-0.3		+280	V	
High side offset VS	VB-25		VB+0.3	V	
High side output HO <sub>1,2,3</sub>	VS-0.3		VB+0.3	V	
Low side output LO <sub>1,2,3</sub>	-0.3		VCC+0.3	V	
Logic input HIN/LIN <sub>1,2,3</sub>	-0.3		VCC+0.3	V	
Allowable offset voltage slew rate dVs/dt			50	V/ns	
Junction temperature T <sub>J</sub>	-40		150	°C	
Storage temperature T <sub>s</sub>	-55		150	°C	
Lead temperature			300	°C	Soldering for 10s
Recommended Operating Conditions					
Low side and logic fixed supply VCC	+4.5		+20.0	V	To ground
High side floating supply VB	VS+10		VS+20	V	
High side offset VS	-5		200	V	
High side output HO <sub>1,2,3</sub>	VS <sub>1,2,3</sub>		VB <sub>1,2,3</sub>	V	
Low side output LO <sub>1,2,3</sub>	0		VCC	V	
Logic input HIN/LIN <sub>1,2,3</sub>	0		5	V	



Ambient temperature $T_A$	-40		105	°C	
Gate driver Electrical Characteristic					
Quiescent VCC supply current1	210	330	450	uA	HIN=LIN=0/5V, ENB=0
Quiescent VCC supply current2		46	80	uA	HIN=LIN=0/5V, ENB=5
Quiescent VBS supply current	25	45	65	uA	HIN=LIN=0V
Floating supply leakage $I_{LK}$			10	uA	VB=VS=220V, VCC=0V
Driving Current $I_{O+}$		1		A	
Driving Current $I_{O-}$		1.2		A	
VCC supply under-voltage positive going threshold	2.9	4.2	5.5	V	
VCC supply under-voltage negative going threshold	2.5	3.8	5.1	V	
VCC supply under-voltage lockout hysteresis		0.4		V	
VBS supply under-voltage positive going threshold	2.5	3.8	4.5	V	
VBS supply under-voltage negative going threshold	2.2	3.5	4.5	V	
VBS supply under-voltage lockout hysteresis		0.3		V	
High level input threshold voltage $V_{IH}$	2.5			V	
Low level input threshold voltage $V_{IL}$			0.8	V	
Turn-on rise time $T_r$		37		ns	$C_L=1nF$
Turn-off fall time $T_f$		30		ns	
Turn-on propagation delay $T_{on}$		120	200	ns	
Turn-off propagation delay $T_{off}$		120	200	ns	
Dead time $D_T$	300	500	700	ns	
Delay matching $M_T$			80	ns	

## 21.2 Recommended Application Diagram

The MCPWM\_SWAP register must be set for the integrated gate drive chip, otherwise the PWM cannot be output normally. Write 0x67 to such register to write BIT[0] to 1, and write other values to write BIT[0] to 0. When the value of MCPWM\_SWAP is 1, it is used to include the pre-drive chip



application environment. The sequence is converted within the logic to facilitate the interconnection of the chip and the drive chip. In general applications, only three sets of MCPWM channels are required, so only three sets of sequences are converted.

Table 21-5 Gate Driver Module LIN/HIN V.S. MCU Pin

Gate Driver Input	G1/2/3	Note
LIN1	P1.4	
HIN1	P1.7	
LIN2	P1.5	
HIN2	P1.8	
LIN3	P1.6	
HIN3	P1.7	

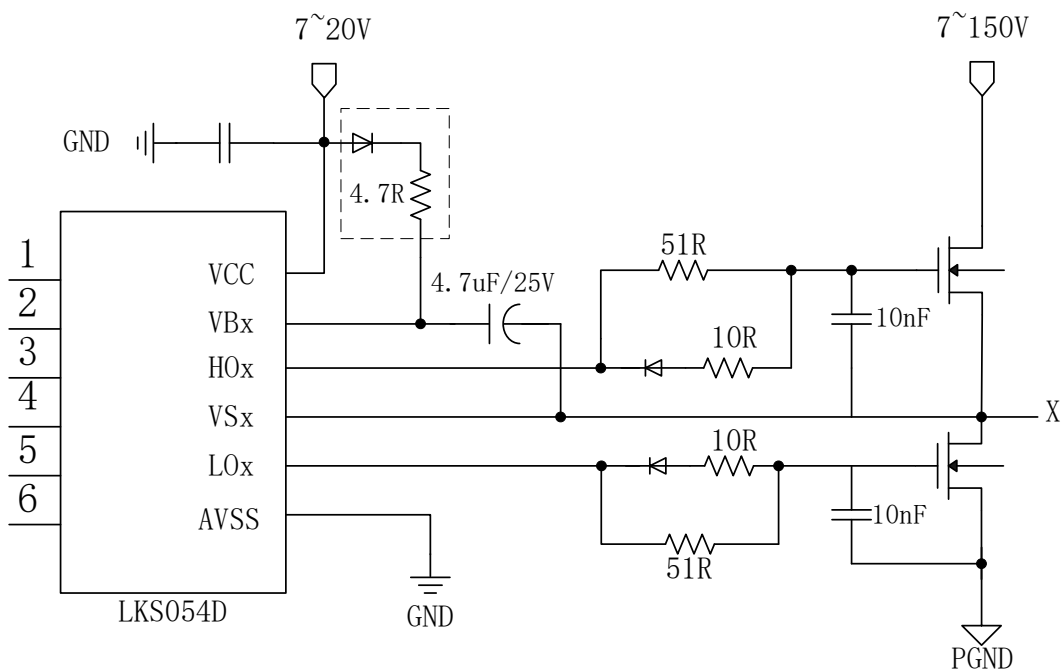

Fig. 21-1 Gate Driver Module G1/G2 Typical Application Diagram

It's recommended to add bootstrap diode between VBx and VCC for Gate Driver Module G1/G2.

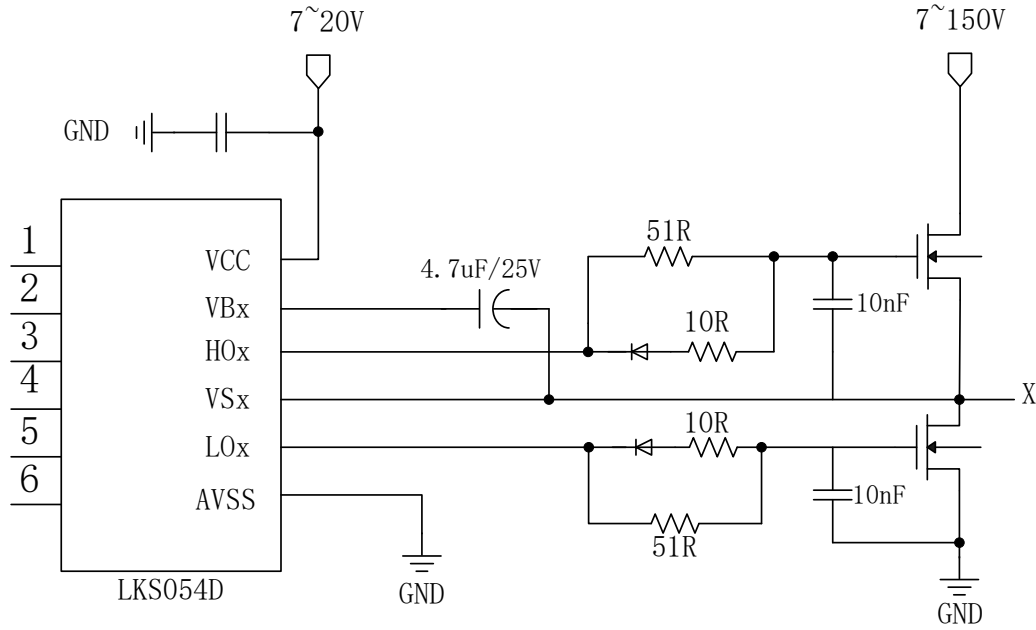

Fig. 21-2 Gate Driver Module G3 typical schematic

Gate Driver Module G3 has built-in bootstrap diode, so the bootstrap on board won't be necessary. But you could still use a bootstrap diode for compatibility concern.

In the figure, only the pins of the gate driver module are displayed, x=1,2,3, corresponding to 3 groups of MOS gate driver outputs.

The corresponding relationship between the input and output polarity of the gate drive module is as follows:

Table. 21-6 Gate Driver Module G1/G2/G3 Truth Table.

{HIN, LIN}	HO	LO	
00	0	0	All off
01	0	1	Low side on
10	1	0	High side on
11	0	0	All on, will trigger hardware short protection

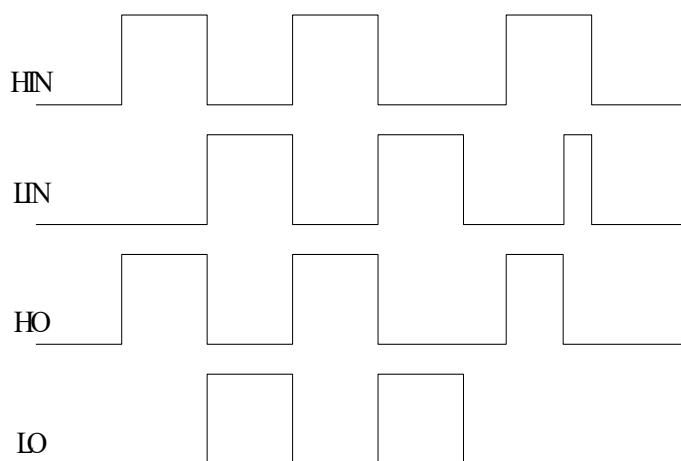

Fig. 21-3 Gate Driver Module G1/G2/G3 polarity

## 22 Special IO Multiplexing

### Notes for Special IO Multiplexing of LKS05x

The SWD protocol includes two signals: SWCLK and SWDIO. The former is a clock signal. To the chip, it is an input and will always be an input. The latter is a data signal. It switches between the input state and the output state during data transmission, and the default is the input state.

Users could use two IOs of SWD as GPIOs. The IO SWCLK could be multiplexed by P2.13, and the IO SWDIO could be multiplexed by P2.0. The precautions are as follows:

- The default state of multiplexing is disabled, and the software needs to write 1 to SYS\_RST\_CFG[6] to enable multiplexing. I.e., after the hard reset of the chip, the initial state of IOs are SWD. Both IOs of SWD shall be provided with pull-up resistors inside the chip (the internal pull-up resistor of the chip is about 10K). When the IOs are used as SWD functions, the pull-up resistors are turned on by default and cannot be turned off. When IO is used as GPIO, the pull-up resistor can be controlled by GPIO2\_PUE[13] and GPIO2\_PUE[0]. P2.0 and P2.13 are forced to be used as SWD function within the 30ms after chip power-on reset. The software can write 1 to SYS\_RST\_CFG[6], but IO function switching won't take effect before 30ms after POR. The 30ms is counted by LRC. There is certain deviation due to the process reason.
- After multiplexing is enabled, tools such as KEIL cannot directly access the chip, i.e., the Debug and erase download functions cannot access the chip since SWD are now general GPIO. If the program needs to be downloaded again, there are two solutions.
- Firstly, it is recommended to use Linko's dedicated offline downloader to erase. It is recommended to leave a certain margin before switching SWD to GPIO, such as about 100ms, to ensure that the offline downloader can erase the chip and prevent the deadlock. This margin is to ensure a successful offline downloader erasing. The greater margin means the greater probability of the successful one-time erasing.
- Secondly, the program should include a multiplexing exit mechanism. For example, a change in some other IO level (usually input), indicates that the SWDIO is required externally, and the software needs to be reconfigured to disable the multiplexing. At this moment, the KEIL function can access the chip via SWD again.

In the packages of SSOP24L, QFN5\*5 40L-0.75 and SOP16L, SWDIO may be directly bonded with P0.0, SWCLK may be directly bonded with P2.6. When P2.6 and SWCLK are bonded together, it is generally recommended to multiplex SWCLK as P2.13 to prevent SWCLK from always being in the input state, which will cause SWCLK to malfunction when the P2.6 signal changes.

If only SWCLK is multiplexed at this time, and SWDIO is not multiplexed, the precautions are the same as above.

For RSTN signal, the default is for the external reset pin of LKS05x chip.

LKS05x can realize the function of RSTN multiplexing as other IOs, and the multiplexed IO is P 0.2.



The precautions are as follows:

- The default state of reset IO multiplexing is disabled, and the software needs to write 1 to SYS\_RST\_CFG[5] to multiplex RSTN as GPIO. I.e., the initial state of P0[2] is RSTN. RSTN is provided with a pull-up resistor inside the chip (the internal pull-up resistor of the chip is about 100K). Attention shall be paid when the application has requirements for initial electric level.
- The default state of P0[2] is used as external reset, and the program can only be executed after the RSTN is released. The application needs to ensure that the RSTN has sufficient protection, such as the peripheral circuit with a pull-up resistor. It is better to add a capacitor.
- After RST IO multiplexing is enabled, the external reset is unavailable to the chip. If a hard reset is required, the reset source can only be power-down/watchdog reset.
- The multiplexing of RSTN does not affect the use of KEIL.



## 23 Ordering Information

Tray Package:

Package Type	Quantity per disc/tube	Quantity in box	Quantity in case
SOP16/ESOP16L	3000/ disc	6000PCS	48000PCS
SSOP24	4000/ disc	8000PCS	64000PCS
SSOP24	50/ pipe	10000PCS	4000/100000PCS
QFN 8*8	260/ disc	2600PCS	15600PCS
QFN 4*4/5*5/6*6	490/ disc	4900PCS	29400PCS
QFN 3*3	5000/ disc	5000PCS	40000PCS
LQFP48/TQFP48 0707	250/ disc	2500PCS	15000PCS
LQFP64 1010	160/ disc	1600PCS	9600PCS
LQFP100 1414	90/ disc	900PCS	5400PCS
TSSOP20/28	4000/ disc	8000PCS	64000PCS

Reel Package:

Package Type		Quantity per disc/tube	Quantity per box	Quantity boxes per case	Quantity per case
Braid -13 inches	SOP/ESOP8	4000	8000	8	64000
Braid -13 inches	SOP/ESOP16	3000	6000	8	48000
Braid -13 inches	SSOP24	4000	8000	8	64000
Braid -13 inches	TSSOP20	4000	8000	8	64000
Braid -13 inches	D/QFN3*3	5000	10000	8	80000
Braid -13 inches	D/QFN4*4	5000	10000	8	80000
Braid -13 inches	D/QFN5*5	5000	10000	8	80000
Pipe	SOP16	50	10000	10	100000
Pipe	SOP14/SSOP24	50	10000	10	100000
Pipe	TSSOP24	54	6480	6	38880



## 24 Version History

Table 24-1 Document Version History

Date	Version No.	Description
2026.01.26	1.78	Add YYWWX Date Code to the 054 G2 driver model
2026.01.20	1.77	Add ADC Configuration Flowchart
2026.01.08	1.76	Remove non-matching model types from the selection table.
2025.12.24	1.75	Revise the block diagrams of gate drive modules G1, G2, G3.
2025.08.22	1.74	Update naming rules
2025.07.24	1.73	Delete 055DL from the model selection table
2025.07.22	1.72	Delete the Flash section: While one Sector is erased and written, an-other Sector can be read and accessed at the same time.
2024.08.21	1.71	Add internal predrive connection diagram
2024.08.04	1.70	Order package information updates to confirm package information by package type and package form
2023.09.25	1.69	Update welding temperature
2023.04.07	1.68	Update package description
2023.03.23	1.67	Modify the LSI accuracy range
2023.03.02	1.66	Change OPA Vcm to 1.65~2.2V
2023.01.14	1.65	Add ordering information
2022.12.13	1.64	Revise 5V LDO output characteristic curve
2022.12.01	1.63	Revise gate driver module G1 parameter
2022.11.19	1.62	Revise date driver parameter description.
2022.11.10	1.61	Add connection resistance between IO and internal analog circuit. Change OPA Vcm to 1.7~2.2V
2022.07.14	1.6	Revise 054D/054DO Gate-driver pin number
2021.12.30	1.5	Revise the Gate-driver description
2020.11.30	1.4	Revise the 054DO pin description
2020.11.3	1.3	Add models 054DO
2020.09.16	1.2	Revise partial parameter function description
2020.08.28	1.1	OPA1 input pin polarity adjustment
2020.04.20	1.0	Initial version

# Disclaimer

LKS and LKO are registered trademarks of Linko.

Linko tries its best to ensure the accuracy and reliability of this document, but reserves the right to change, correct, enhance, modify the product and/or document at any time without prior notice.

Users can obtain the latest information before placing an order.

Customers should select the appropriate Linko product for their application needs and design, validate and test your application in detail to ensure that it meets the appropriate standards and any safety, security or other requirements. The customer is solely responsible for this.

Linko hereby acknowledges that no intellectual property licenses, express or implied, are granted to Linko or to third parties.

Resale of Linko products on terms other than those set forth herein shall void any warranty warranties made by Linko for such products.

Prohibited for military use or life care and maintenance systems.

For earlier versions, please refer to this document.

