



Linko Semiconductor Co., Ltd.

# ***LKS32MC07X Datasheet***

© 2023, all rights reserved by Linko Semiconductor  
Confidential. Unauthorized dissemination is prohibited.



©2023 All rights reserved by Linko Semiconductor Confidential. Unauthorized dissemination is prohibited.

# 1 Overview

## 1.1 Functions

LKS32MC07x is a 32-bit MCU targeting motor control applications, integrating all modules required by common motor control systems.

### ● Features

- 96MHz 32-bit Cortex-M0 core
- Customized instruction set DSP for motor control
- Ultra low power sleep mode, 10uA sleep current with MCU low power consumption
- Industrial temperature range
- High ESD and group pulse reliability

### ● Operating Conditions

- 2.5~5.5V power supply, with an integrated internal 5V LDO for partial power supply for internal MCU of chip
- Operating Conditions: -40~105°C

### ● Clock

- 8MHz built-in high-precision RC oscillator, with an accuracy of  $\pm 1\%$  at -40 ~ 105 °C
- 32KHz built-in low-speed clock for low-power mode
- Operating on an external 8MHz crystal is available
- Internal PLL up to 96 MHz

### ● Flash

- Built-in flash including 64kB/128kB main area and 1.5kB NVR
- Endurance: 100,000 Cycles(min)
- Data retention: more than 100 years under room temperature 25 °C
- Single byte program: 7.5us(max), Sector erase: 5ms(max)
- Sector size 512bytes, supporting Sector erase/program
- Flash data anti-theft by programming the last word of flash to any words other than 0xFFFFFFFF

### ● SRAM

- Built-in 12kB SRAM

### ● Peripheral module

- Two UARTs
- One SPI, support master-slave mode
- One IIC, support master-slave mode
- One CAN-bus (Some chips without CAN)
- Two 16-bit standard timers (TIM), support capture and edge-aligned PWM function



- Two 32-bit standard timers (TIM), support capture and edge-aligned PWM function; support orthogonal code input, CW/CCW input, and pulse&symbol input
  - Motor control PWM module, supports 12 channels/6 pairs of PWM waveform output, independent dead-band control
  - Hall signal interface with speed measurement and debouncing function
  - Hardware watchdog
  - 4 Groups of 16bit GPIO at the most. 8 GPIOs could be used as wake-up source。 15 GPIOs could be used as external IRQ source
- **Simulation module**
    - Two 12bit SAR ADC, simultaneous double sampling, 3MSPS sampling and conversion rate, and each sampling circuit supports up to 16 channels, including 4 OPA outputs and 10 external ADC channels for a total of 14 optional ADC channel signals
    - Four operational amplifiers. Differential PGA mode is available.
    - Three comparators. Hysteresis mode is available.
    - Two 12bit digital-to-analog converter (DAC)
    - $\pm 2$  °C built-in temperature sensor
    - 1.2V 0.8% built-in linear regulator
    - Low-power LDO and power monitoring circuit
    - RC oscillator with high precision and low temperature drift
    - Crystal oscillator circuits

## 1.2 Performance advantages

- High reliability, high integration level, small package size, saving BOM cost;
- Integrated 4 channels high-speed OPAs and 3 channels comparators, meeting the needs of different system topology like single resistance/double resistance/three resistance current sampling;
- High-speed OPA is integrated with over-voltage protection circuit, which allows high-voltage common-mode signals to be input, which could support direct current sampling of MOSFET resistance with the simplest circuit topology;
- Integrated hardware MOSFET temperature drift compensation circuit to ensure current sampling accuracy;
- Via a proprietary technique, ADC and high-speed OPA could cooperate well, making them able to handle a wider current dynamic range, while ensuring the sampling precision of high-speed small current and low-speed high current;
- The control circuit is simple and efficient, with strong anti-interference ability, stable and reliable;
- 2.5V~5.5V single power supply ensures the universality of system power supply;



- Supports IEC/UL60730 functional safety certification

Applicable to control systems such as inductive BLDC/non-inductive BLDC/inductive FOC/non-inductive FOC and stepper motors, permanent magnet synchronous and asynchronous motors.



### 1.3 Naming Conventions

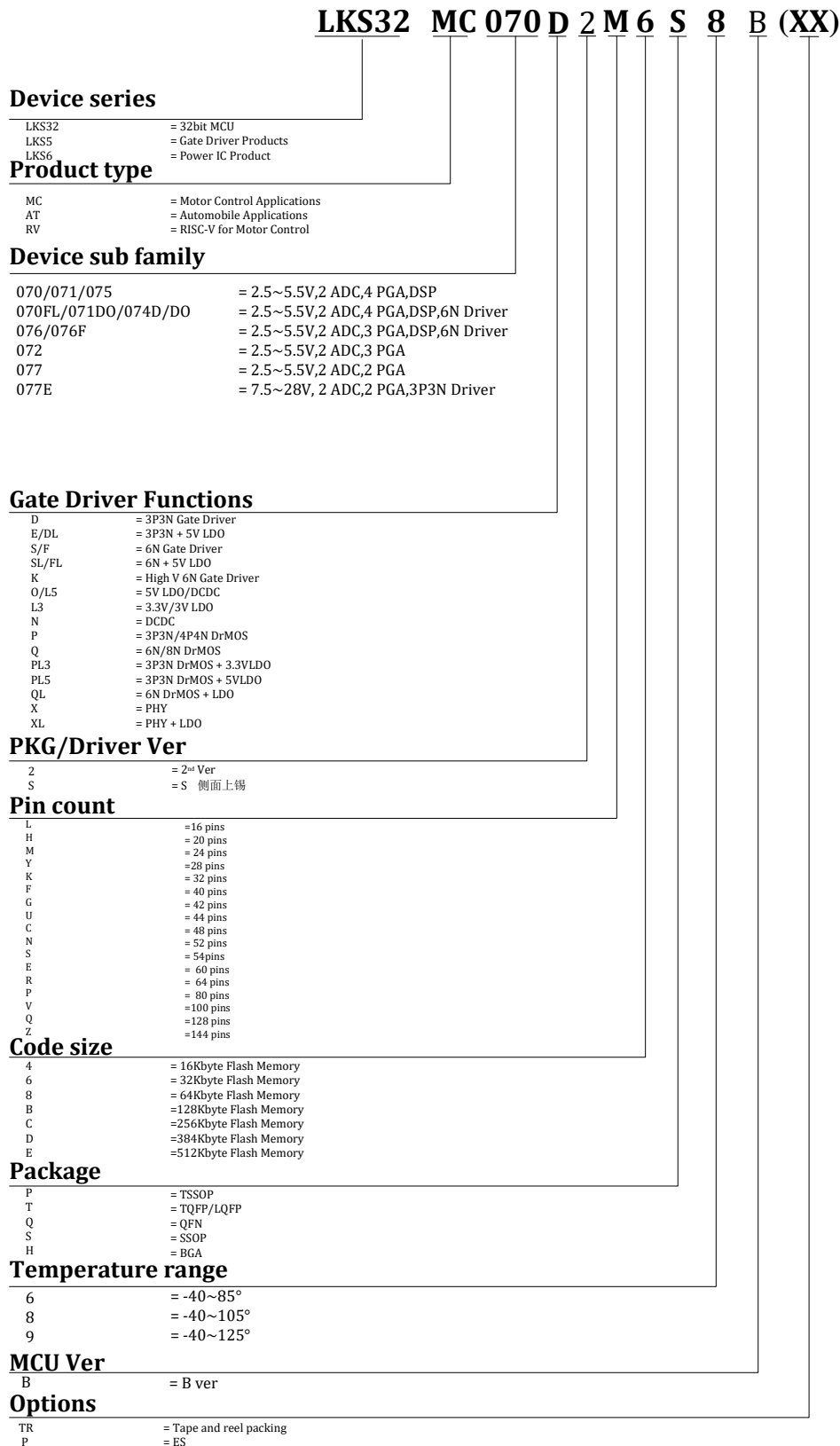

Fig.1-1 Naming Conventions of Linko Components



### 1.4 Resource Diagram

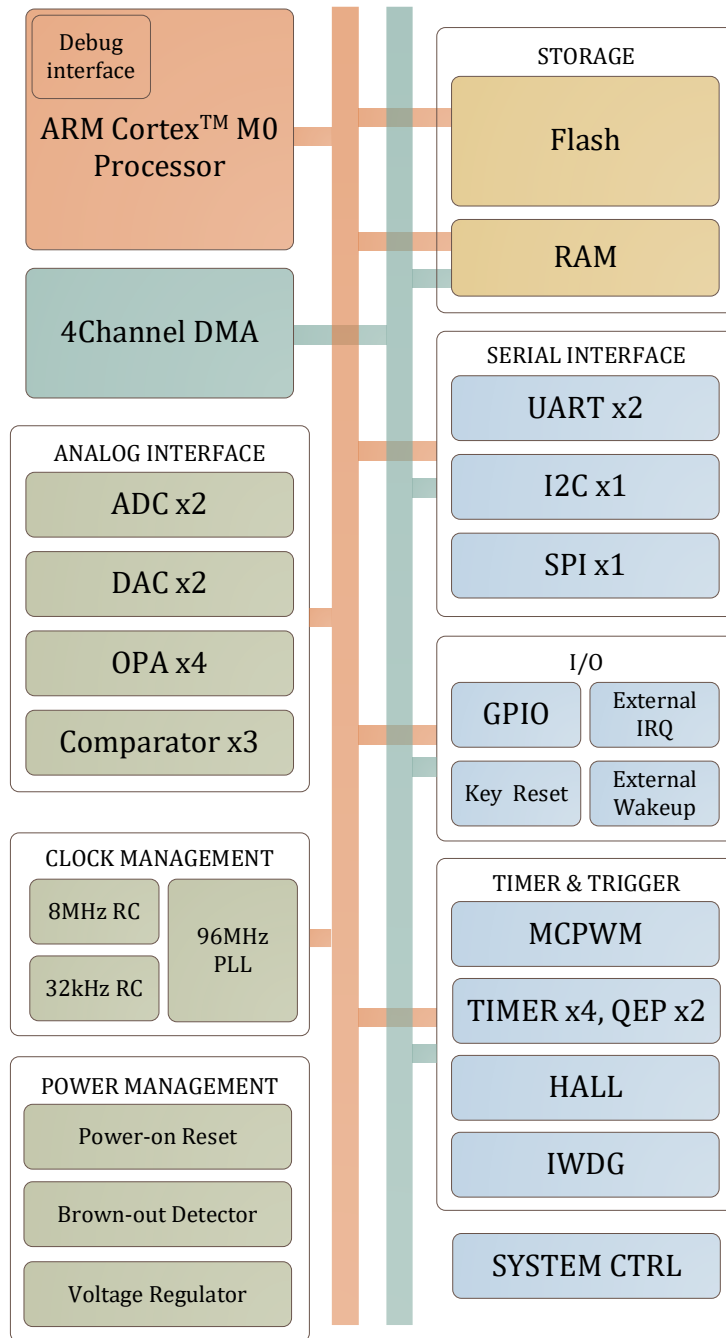
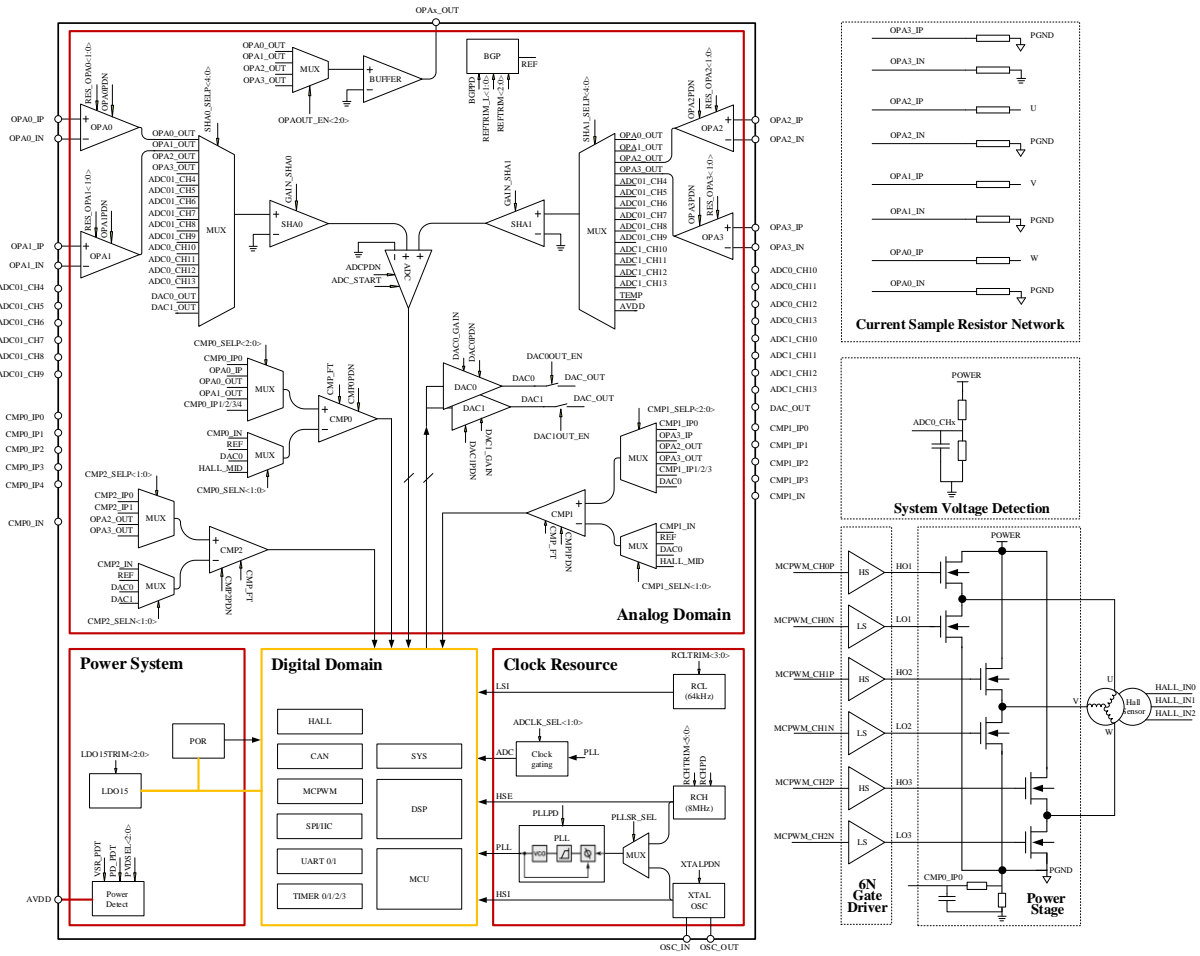

Fig.1-2 LKS32MC07x Resource Diagram

### 1.5 FOC System Example



\* ADC 01\_CH4 ~ ADC 01\_CH9 are common channels for ADC0 and ADC 1

Fig.1-3 LKS32MC07x Simplified Schematic of FOC System

## 2 Device selection table

Table 2-1 LKS07x Series Device Selection Table

	Frequency (MHz)	Flash (kB)	RAM (kB)	ADC ch.	DAC	Comparator	Comparator ch.	OPA	HALL	SPI	IIC	UART	CAN	Temp. Sensor	PLL	QEP	Gate driver	Gate Driver current (A)	Pre-drive supply (V)	Gate floating voltage (V)	Others	Package
LKS32MC070RBT8	96	128	12	14	12BITx2	3	11	4	3	1	1	2	Yes	Yes	Yes	Yes						LQFP64
LKS32MC071CBT8	96	128	12	13	12BITx2	3	11	4	3	1	1	2	Yes	Yes	Yes	Yes						LQFP48, TQFP48
LKS32MC071C8T8	96	64	12	13	12BITx2	3	11	4	3	1	1	2		Yes	Yes	Yes						LQFP48, TQFP48
LKS32MC072KBQ8	96	128	12	8	12BITx2	3	7	3	3	1	1	2		Yes	Yes	Yes						QFN5*5 32L-0.75
LKS32MC072KBT8	96	128	12	9	12BITx2	2	5	0	3	1	1	2		Yes	Yes	Yes						LQFP32
LKS32MC073HBQ8	96	128	12	4	12BITx2	2	4	1	3	0	1	2		Yes	Yes	Yes						QFN3*3 20L-0.75
LKS32MC077MBS8	96	64	12	6	12BITx2	3	6	2	3	1	1	2		Yes	Yes	Yes						SSOP24L



### 3 Pin Assignment

#### 3.1 Pin Assignment and Pin Function Description

##### 3.1.1 LKS32MC070RBT8



Fig.3-1 LKS32MC070RBT8 Pin Assignment

The red pin in the pin assignment figures below has built-in pull-up resistors: RSTN has a 300kΩ built-in pull-up resistor, which is enabled automatically after power-up. SWDIO/SWCLK has a 12kΩ built-in pull-up resistor, which is enabled automatically after power-up. The remaining red pins have 12kΩ built-in pull-up resistors, which could be software-enabled.

Table 3-1 LKS32MC070RBT8 Pin Function Description

1	P0_0	P0.0
	CLKO	Clock output (for debugging)
	MCPWM_BKIN0	PWM shutdown input signal 0
	UART0_RXD	Serial port 0 receive (send)
	SPI_DI	SPI Data In (Out)



	CLUOUT0	CLU0 output
	ADC01_CH4	ADC 0/ADC1 Channel 4
	DAC0_OUT	DAC0 output
	DAC1_OUT	DAC1 Output
	FLT	IO filtering
	EXTI0	External GPIO Interrupt Signal 0
	WK0	External wake-up signal 0
	PU	Built-in 12kΩ pull-up resistor, software switchable
2	P0_1	P0.1
	ADC01_CH6	ADC 0/ADC1 Channel 6
	EXTI1	External GPIO Interrupt Signal 1
3	P0_2	P0.2
	CLUOUT1	CLU1 output
	RST_n	Reset pin, P0.2 used as RSTN by default. It is recommended to connect a 10 nF to 100 nF capacitor to ground and place a 12 K to 20 K pull-up resistor between RSTN and AVDD. If there is an external pull-up resistor, the capacitance of RSTN should be 100 nF. P0.2 can be switched as a GPIO, which turns off the 12 kΩ pull-up resistor.
	FLT	IO filtering
	EXTI2	External GPIO Interrupt Signal 2
	WK1	External wake-up signal 1
	PU	Built-in 12kΩ pull-up resistor, software switchable
4	GND	Chip ground. It is strongly recommended that multiple ground pins be grounded uniformly on the PCB.
5	AVDD	Chip power supply, power supply range 2.5 ~ 5.5V
6	P3_2	P3.2
	MCPWM_CH3P	PWM Channel 3 High-Side
	CLUOUT2	CLU2 output
7	P3_4	P3.4
	MCPWM_CH3N	PWM Channel 3 Low Side
8	P0_3	P0.3
	MCPWM_CH4P	PWM Channel 4 High Side
	SCL	I2C clock
	TIM2_CH0	Timer2 channel 0
	ADC01_CH7	ADC0/ADC1 Channel 7
	EXTI3	External GPIO Interrupt Signal 3
	PU	Built-in 12kΩ pull-up resistor, software switchable
9	P0_4	P0.4
	MCPWM_CH4N	PWM Channel 4 Low Side
	SDA	I2C data
	TIM2_CH1	Timer2 channel 1
	ADC01_CH8	ADC0/ADC1 Channel 8
	PU	Built-in 12kΩ pull-up resistor, software switchable



10	P0_5	P0.5
	HALL_IN0	HALL interface input 0
	MCPWM_CH5P	PWM Channel 5 High Side
	QEPO_Z	QEPO Encoder Phase Z
	ADC01_CH9	ADC0/ADC1 Channel 9
11	P0_6	P0.6
	HALL_IN1	HALL interface input 1
	MCPWM_CH5N	PWM Channel 5 Low Side
	UART1_RXD	Serial port 1 receive (send)
	SCL	I2C clock
	TIM1_CH0	Timer1 channel 0
	CAN_RX	CAN receive
	CMP2_IN	Comparator 2 Negative Terminal Input
	FLT	IO filtering
	EXTI4	External GPIO Interrupt 4
	WK2	External wake-up signal 2
	PU	Built-in 12kΩ pull-up resistor, software switchable
12	P0_7	P0.7
	HALL_IN2	HALL interface input 2
	MCPWM_BKIN1	PWM Shutdown Input Signal 1
	UART1_TXD	Serial port 1 send (receive)
	SDA	I2C data
	TIM1_CH1	Timer1 channel 1
	CAN_TX	Can sender
	CMP2_IP0	Positive input 0 of comparator 2
	FLT	IO filtering
	PU	Built-in 12kΩ pull-up resistor, software switchable
13	P1_1	P1.1
	SPI_CS	SPI chip select
	EXTI5	External GPIO Interrupt 5
14	P2_11	P2.11
	MCPWM_CH1P	PWM Channel 1 High Side
	TIM2_CH0	Timer2 channel 0
	CMP2_IP1	Positive Input 1 of Comparator 2
15	P2_12	P2.12
	MCPWM_CH1N	PWM Channel 1 Low Side
	SPI_CS	SPI chip select
	TIM2_CH1	Timer2 channel 1
	ADC_TRIGGER0	ADC0 trigger signal output (for debugging)
	CLUOUT3	CLU3 output
	EXTI6	External GPIO Interrupt 6
16	P0_8	P0.8
17	P0_9	P0.9



	SCL	I2C clock
	TIM2_CH0	Timer2 channel 0
	PU	Built-in 12kΩ pull-up resistor, software switchable
18	P0_10	P0.10
	SDA	I2C data
	TIM2_CH1	Timer2 channel 1
19	P0_11	P0.11
	HALL_IN0	HALL interface input 0
	TIM3_CH0	Timer3 channel 0
	ADC1_CH11	ADC1 Channel 11
	CMP0_IP1	Comparator 0 positive input 1
	FLT	IO filtering
	EXTI7	External GPIO Interrupt Signal 7
	WK3	External wake-up signal 3
20	P0_12	P0.12
	HALL_IN1	HALL interface input 1
	TIM3_CH1	Timer3 channel 1
	CAN_RX	CAN receive
	ADC1_CH12	ADC1 Channel 12
	CMP0_IP2	Comparator 0 positive input 2
	FLT	IO filtering
21	P0_13	P0.13
	HALL_IN2	HALL interface input 2
	QEP0_Z	QEP0 Encoder Phase Z
	CAN_TX	Can sender
	ADC1_CH13	ADC1 Channel 13
	CMP0_IP3	Comparator 0 positive input 3
	FLT	IO filtering
22	P0_14	P0.14
	CMP0_OUT	Comparator 0 Output
	MCPWM_BKIN1	PWM Shutdown Input Signal 1
	UART0_TXD	Serial port 0 send (receive)
	SPI_CLK	SPI clock
	SCL	I2C clock
	TIM0_CH1	Timer0 channel 1
	QEP1_Z	Phase Z of QEP1 encoder
	ADC_TRIGGER0	ADC0 trigger signal output (for debugging)
	SIF	Single line communication
	CLUOUT0	CLU0 output
	ADC0_CH10	ADC0 Channel 10
	CMP0_IP4	Comparator 0 positive input 4
	FLT	IO filtering
	EXTI8	External GPIO Interrupt Signal 8



	WK4	External wake-up signal 4
	PU	Built-in 12kΩ pull-up resistor, software switchable
23	P0_15	P0.15
	CMP2_OUT	Comparator 2 Output
	MCPWM_CH0P	PWM Channel 0 High Side
	UART0_RXD	Serial port 0 receive (send)
	SPI_DO	SPI Data Output (Input)
	SDA	I2C data
	TIM0_CH0	Timer0 channel 0
	ADC_TRIGGER1	ADC1 trigger signal output (for debugging)
	CMP0_IN	Comparator 0 negative input
	FLT	IO filtering
	EXTI9	External GPIO Interrupt 9
	PU	Built-in 12kΩ pull-up resistor, software switchable
	24	P1_0
MCPWM_CH0N		PWM Channel 0 Low Side
UART0_TXD		Serial port 0 send (receive)
SPI_DI		SPI Data In (Out)
TIM0_BKIN		TIMERO _ FAIL signal from GPIO
EXTI10		External GPIO Interrupt Signal 10
PU		Built-in 12kΩ pull-up resistor, software switchable
25	P3_6	P3.6
26	P1_2	P1.2
	TIM3_CH0	Timer3 channel 0
27	P1_3	P1.3
	TIM3_CH1	Timer3 channel 1
	ADC01_CH5	ADC 0/ADC1 Channel 5
	PU	Built-in 12kΩ pull-up resistor, software switchable
28	P3_5	P3.5
	OPA0_IP	Positive terminal input of operational amplifier 0
29	P3_7	P3.7
	OPA0_IN	Input of negative terminal of operational amplifier 0
30	P2_7	P2.7
	CLKO	Clock output (for debugging)
	UART0_TXD	Serial port 0 send (receive)
	TIM0_CH0	Timer0 channel 0
	TIM3_CH1	Timer3 channel 1
	ADC_TRIGGER1	ADC1 trigger signal output (for debugging)
	CAN_TX	Can sender
	CLUOUT1	CLU1 output
	ADC0_CH11	ADC0 Channel 11
	OPAx_OUT	Op Amp Output
	LDO15	1.5V LDO Output



	REF	Reference Voltage
	EXTI11	External GPIO Interrupt Signal 11
	WK6	External wake-up signal 6
	PU	Built-in 12kΩ pull-up resistor, software switchable
31	P3_0	P3.0
	OPA1_IP	Positive input of operational amplifier 1
32	P3_1	P3.1
	OPA1_IN	Op Amp 1 Negative Input
33	P2_8	P2.8
	UART1_RXD	Serial port 1 receive (send)
	SPI_DO	SPI Data Output (Input)
	TIM3_CH0	Timer3 channel 0
	OSC_IN	External crystal pin
	PU	Built-in 12kΩ pull-up resistor, software switchable
34	P3_9	P3.9
	UART1_TXD	Serial port 1 send (receive)
	TIM3_CH1	Timer3 channel 1
	OSC_OUT	External crystal pin
	PU	Built-in 12kΩ pull-up resistor, software switchable
35	P3_13	P3.13
36	P1_12	P1.12
37	P1_13	P1.13
	MCPWM_CH5P	PWM Channel 5 High Side
	SPI_CLK	SPI clock
	TIM0_CH0	Timer0 channel 0
38	P1_14	P1.14
	MCPWM_CH5N	PWM Channel 5 Low Side
	SPI_DO	SPI Data Output (Input)
	TIM0_CH1	Timer0 channel 1
39	P1_15	P1.15
	MCPWM_CH4P	PWM Channel 4 High Side
	SPI_DI	SPI Data In (Out)
	TIM2_CH0	Timer2 channel 0
40	P2_0	P2.0
	MCPWM_CH4N	PWM Channel 4 Low Side
	SPI_CS	SPI chip select
	TIM2_CH1	Timer2 channel 1
41	P1_4	P1.4
	MCPWM_CH0P	PWM Channel 0 High Side
	QEP0_Z	QEP0 Encoder Phase Z
42	P1_5	P1.5
	MCPWM_CH0N	PWM Channel 0 Low Side
43	P1_6	P1.6



	MCPWM_CH1P	PWM Channel 1 High Side
44	P1_7	P1.7
	MCPWM_CH1N	PWM Channel 1 Low Side
45	P1_8	P1.8
	MCPWM_CH2P	PWM Channel 2 High Side
46	P1_9	P1.9
	MCPWM_CH2N	PWM Channel 2 Low Side
47	P1_10	P1.10
	MCPWM_CH3P	PWM Channel 3 High-Side
	UART0_RXD	Serial port 0 receive (send)
	SCL	I2C clock
	TIM0_CH0	Timer0 channel 0
	ADC_TRIGGER0	ADC0 trigger signal output (for debugging)
	ADC0_CH13	ADC0 Channel 13
	EXTI12	External GPIO Interrupt Signal 12
PU	Built-in 12kΩ pull-up resistor, software switchable	
48	P1_11	P1.11
	MCPWM_CH3N	PWM Channel 3 Low Side
	UART0_TXD	Serial port 0 send (receive)
	SDA	I2C data
	TIM0_CH1	Timer0 channel 1
	ADC_TRIGGER1	ADC1 trigger signal output (for debugging)
	SIF	Single line communication
	CLUOUT2	CLU2 output
PU	Built-in 12kΩ pull-up resistor, software switchable	
49	P3_10	P3.10
	MCPWM_CH4P	PWM Channel 4 High Side
	OPA2_IP	Positive input of operational amplifier 2
50	P3_11	P3.11
	MCPWM_CH4N	PWM Channel 4 Low Side
	OPA2_IN	Op Amp 2 Negative Input
51	P2_9	P2.9
	MCPWM_CH5P	PWM Channel 5 High Side
	SPI_DI	SPI Data In (Out)
	SCL	I2C clock
	ADC0_CH12	ADC0 Channel 12
	CMP0_IP0	Comparator 0 positive input 0
	PU	Built-in 12kΩ pull-up resistor, software switchable
52	P2_10	P2.10
	MCPWM_CH5N	PWM Channel 5 Low Side
	SPI_DO	SPI Data Output (Input)
	SDA	I2C data
	PU	Built-in 12kΩ pull-up resistor, software switchable



53	P3_14	P3.14
	OPA3_IN	Op Amp 3 Negative Input
54	P3_15	P3.15
	OPA3_IP	Positive input of operational amplifier 3
55	P2_1	P2.1
	SPI_CLK	SPI clock
	ADC1_CH10	ADC1 Channel 10
	CMP1_IP0	Positive input 0 of comparator 1
56	P3_12	P3.12
57	P2_2	P2.2
	QEP1_Z	Phase Z of QEP1 encoder
	CMP1_IN	Comparator 1 Negative Input
58	P2_3	P2.3
	CMP1_OUT	Comparator 1 Output
	MCPWM_BKIN0	PWM shutdown input signal 0
	SPI_CS	SPI chip select
	TIM0_CH1	Timer0 channel 1
	QEP0_Z	QEP0 Encoder Phase Z
	CLUOUT3	CLU3 output
	FLT	IO filtering
	EXTI13	External GPIO Interrupt Signal 13
59	P2_4	P2.4
	CMP0_OUT	Comparator 0 Output
	HALL_IN0	HALL interface input 0
	MCPWM_CH2P	PWM Channel 2 High Side
	UART1_RXD	Serial port 1 receive (send)
	SPI_CLK	SPI clock
	TIM1_CH0	Timer1 channel 0
	TIM2_CH0	Timer2 channel 0
	ADC_TRIGGER0	ADC0 trigger signal output (for debugging)
	CAN_RX	CAN receive
	CMP1_IP1	Comparator 1 positive input 1
	FLT	IO filtering
	EXTI14	External GPIO Interrupt Signal 14
	WK5	External wake-up signal 5
	PU	Built-in 12kΩ pull-up resistor, software switchable
60	P2_5	P2.5
	CMP1_OUT	Comparator 1 Output
	HALL_IN1	HALL interface input 1
	MCPWM_CH2N	PWM Channel 2 Low Side
	UART1_TXD	Serial port 1 send (receive)
	SPI_DO	SPI Data Output (Input)
	TIM1_CH1	Timer1 channel 1



	TIM2_CH1	Timer2 channel 1
	ADC_TRIGGER1	ADC1 trigger signal output (for debugging)
	CAN_TX	Can sender
	CMP1_IP2	Comparator 1 positive input 2
	FLT	IO filtering
	PU	Built-in 12kΩ pull-up resistor, software switchable
61	P2_6	P2.6
	CMP2_OUT	Comparator 2 Output
	HALL_IN2	HALL interface input 2
	MCPWM_CH3P	PWM Channel 3 High-Side
	TIM0_BKIN	TIMER0 _ FAIL signal from GPIO
	TIM3_CH0	Timer3 channel 0
	ADC_TRIGGER0	ADC0 trigger signal output (for debugging)
	SIF	Single line communication
	CLUOUT0	CLU0 output
	CMP1_IP3	Comparator 1 positive input 3
	FLT	IO filtering
	PU	Built-in 12kΩ pull-up resistor, software switchable
62	P2_13	P2.13
	MCPWM_CH3N	PWM Channel 3 Low Side
	UART0_TXD	Serial port 0 send (receive)
	SPI_DO	SPI Data Output (Input)
	SCL	I2C clock
	TIM3_CH1	Timer3 channel 1
PU	Built-in 12kΩ pull-up resistor, software switchable	
63	P2_14	P2.14
	SWCLK	SWD clock
	SPI_DI	SPI Data In (Out)
	SCL	I2C clock
	PU	Built-in 12kΩ pull-up resistor, software switchable
64	P2_15	P2.15
	SWDIO	SWD data
	UART0_RXD	Serial port 0 receive (send)
	SPI_CS	SPI chip select
	SDA	I2C data
	TIM2_CH1	Timer2 channel 1
	CLUOUT1	CLU1 output
	EXTI15	External GPIO Interrupt 15
	WK7	External wake-up signal 7
	PU	Built-in 12kΩ pull-up resistor, software switchable

3.1.2 LKS32MC071C8T8



Fig.3-2 LKS32MC071C8T8 Pin Assignment

\* The red PIN pin in the figure has a built-in resistor that pulls up to AVDD: The RSTN has an internal 300 kΩ pull-up resistor and is fixed on pull-up SWDIO/SWCLK has a 12kΩ internal pull-up resistor and is fixed on pull-up. The remaining red PIN pins have built-in 12 kΩ pull-up resistors, which can be turned on and off by software control.

Table3-2 LKS32MC071C8T8 Pin Function Description

1	P0_0	P0.0
	CLKO	Clock output (for debugging)
	MCPWM_BKIN0	PWM shutdown input signal 0
	UART0_RXD	Serial port 0 receive (send)
	SPI_DI	SPI Data In (Out)
	CLUOUT0	CLU0 output
	ADC01_CH4	ADC 0/ADC1 Channel 4
	DAC0_OUT	DAC0 output
	DAC1_OUT	DAC1 Output
	FLT	IO filtering



	EXTI0	External GPIO Interrupt Signal 0
	WK0	External wake-up signal 0
	PU	Built-in 12kΩ pull-up resistor, software switchable
2	P0_2	P0.2
	CLUOUT1	CLU1 output
	RST_n	Reset pin, P0.2 used as RSTN by default. It is recommended to connect a 10 nF to 100 nF capacitor to ground and place a 12 K to 20 K pull-up resistor between RSTN and AVDD. If there is an external pull-up resistor, the capacitance of RSTN should be 100 nF. P0.2 can be switched as a GPIO, which turns off the 12 kΩ pull-up resistor.
	FLT	IO filtering
	EXTI2	External GPIO Interrupt Signal 2
	WK1	External wake-up signal 1
	PU	Built-in 12kΩ pull-up resistor, software switchable
	3	GND
4	AVDD	Chip power supply, power supply range 2.5 ~ 5.5V
5	P3_2	P3.2
	MCPWM_CH3P	PWM Channel 3 High-Side
	CLUOUT2	CLU2 output
6	P0_3	P0.3
	MCPWM_CH4P	PWM Channel 4 High Side
	SCL	I2C clock
	TIM2_CH0	Timer2 channel 0
	ADC01_CH7	ADC0/ADC1 Channel 7
	EXTI3	External GPIO Interrupt Signal 3
	PU	Built-in 12kΩ pull-up resistor, software switchable
7	P0_4	P0.4
	MCPWM_CH4N	PWM Channel 4 Low Side
	SDA	I2C data
	TIM2_CH1	Timer2 channel 1
	ADC01_CH8	ADC0/ADC1 Channel 8
	PU	Built-in 12kΩ pull-up resistor, software switchable
8	P0_5	P0.5
	HALL_IN0	HALL interface input 0
	MCPWM_CH5P	PWM Channel 5 High Side
	QEPO_Z	QEPO Encoder Phase Z
	ADC01_CH9	ADC0/ADC1 Channel 9
9	P0_6	P0.6
	HALL_IN1	HALL interface input 1
	MCPWM_CH5N	PWM Channel 5 Low Side
	UART1_RXD	Serial port 1 receive (send)
	SCL	I2C clock



	TIM1_CH0	Timer1 channel 0
	CMP2_IN	Comparator 2 Negative Terminal Input
	FLT	IO filtering
	EXTI4	External GPIO Interrupt 4
	WK2	External wake-up signal 2
	PU	Built-in 12kΩ pull-up resistor; software switchable
10	P0_7	P0.7
	HALL_IN2	HALL interface input 2
	MCPWM_BKIN1	PWM Shutdown Input Signal 1
	UART1_TXD	Serial port 1 send (receive)
	SDA	I2C data
	TIM1_CH1	Timer1 channel 1
	CMP2_IP0	Positive input 0 of comparator 2
	FLT	IO filtering
PU	Built-in 12kΩ pull-up resistor; software switchable	
11	P2_11	P2.11
	MCPWM_CH1P	PWM Channel 1 High Side
	TIM2_CH0	Timer2 channel 0
	CMP2_IP1	Positive Input 1 of Comparator 2
12	P2_12	P2.12
	MCPWM_CH1N	PWM Channel 1 Low Side
	SPI_CS	SPI chip select
	TIM2_CH1	Timer2 channel 1
	ADC_TRIGGER0	ADC0 trigger signal output (for debugging)
	CLUOUT3	CLU3 output
13	EXTI6	External GPIO Interrupt 6
	P0_11	P0.11
	HALL_IN0	HALL interface input 0
	TIM3_CH0	Timer3 channel 0
	ADC1_CH11	ADC1 Channel 11
	CMP0_IP1	Comparator 0 positive input 1
	FLT	IO filtering
	EXTI7	External GPIO Interrupt Signal 7
14	WK3	External wake-up signal 3
	P0_12	P0.12
	HALL_IN1	HALL interface input 1
	TIM3_CH1	Timer3 channel 1
	ADC1_CH12	ADC1 Channel 12
	CMP0_IP2	Comparator 0 positive input 2
	FLT	IO filtering
15	P0_13	P0.13
	HALL_IN2	HALL interface input 2
	QEP0_Z	QEP0 Encoder Phase Z

	ADC1_CH13	ADC1 Channel 13
	CMP0_IP3	Comparator 0 positive input 3
	FLT	IO filtering
16	P0_14	P0.14
	CMP0_OUT	Comparator 0 Output
	MCPWM_BKIN1	PWM Shutdown Input Signal 1
	UART0_TXD	Serial port 0 send (receive)
	SPI_CLK	SPI clock
	SCL	I2C clock
	TIM0_CH1	Timer0 channel 1
	QEP1_Z	Phase Z of QEP1 encoder
	ADC_TRIGGER0	ADC0 trigger signal output (for debugging)
	SIF	Single line communication
	CLUOUT0	CLU0 output
	ADC0_CH10	ADC0 Channel 10
	CMP0_IP4	Comparator 0 positive input 4
	FLT	IO filtering
	EXTI8	External GPIO Interrupt Signal 8
	WK4	External wake-up signal 4
PU	Built-in 12kΩ pull-up resistor, software switchable	
17	P0_15	P0.15
	CMP2_OUT	Comparator 2 Output
	MCPWM_CH0P	PWM Channel 0 High Side
	UART0_RXD	Serial port 0 receive (send)
	SPI_DO	SPI Data Output (Input)
	SDA	I2C data
	TIM0_CH0	Timer0 channel 0
	ADC_TRIGGER1	ADC1 trigger signal output (for debugging)
	CMP0_IN	Comparator 0 negative input
	FLT	IO filtering
	EXTI9	External GPIO Interrupt 9
PU	Built-in 12kΩ pull-up resistor, software switchable	
18	P1_0	P1.0
	MCPWM_CH0N	PWM Channel 0 Low Side
	UART0_TXD	Serial port 0 send (receive)
	SPI_DI	SPI Data In (Out)
	TIM0_BKIN	TIMER0 _ FAIL signal from GPIO
	EXTI10	External GPIO Interrupt Signal 10
PU	Built-in 12kΩ pull-up resistor, software switchable	
19	P1_3	P1.3
	TIM3_CH1	Timer3 channel 1
	ADC01_CH5	ADC 0/ADC1 Channel 5
	PU	Built-in 12kΩ pull-up resistor, software switchable



20	P3_5	P3.5
	OPA0_IP	Positive terminal input of operational amplifier 0
21	P3_7	P3.7
	OPA0_IN	Input of negative terminal of operational amplifier 0
22	P2_7	P2.7
	CLKO	Clock output (for debugging)
	UART0_TXD	Serial port 0 send (receive)
	TIM0_CH0	Timer0 channel 0
	TIM3_CH1	Timer3 channel 1
	ADC_TRIGGER1	ADC1 trigger signal output (for debugging)
	CLUOUT1	CLU1 output
	ADC0_CH11	ADC0 Channel 11
	OPAx_OUT	Op Amp Output
	LDO15	1.5V LDO Output
	REF	Reference Voltage
	EXTI11	External GPIO Interrupt Signal 11
	WK6	External wake-up signal 6
	PU	Built-in 12kΩ pull-up resistor; software switchable
23	P3_0	P3.0
	OPA1_IP	Positive input of operational amplifier 1
24	P3_1	P3.1
	OPA1_IN	Op Amp 1 Negative Input
25	P2_8	P2.8
	UART1_RXD	Serial port 1 receive (send)
	SPI_DO	SPI Data Output (Input)
	TIM3_CH0	Timer3 channel 0
	OSC_IN	External crystal pin
	PU	Built-in 12kΩ pull-up resistor; software switchable
26	P3_9	P3.9
	UART1_TXD	Serial port 1 send (receive)
	TIM3_CH1	Timer3 channel 1
	OSC_OUT	External crystal pin
	PU	Built-in 12kΩ pull-up resistor; software switchable
27	P1_4	P1.4
	MCPWM_CH0P	PWM Channel 0 High Side
	QEP0_Z	QEP0 Encoder Phase Z
28	P1_5	P1.5
	MCPWM_CH0N	PWM Channel 0 Low Side
29	P1_6	P1.6
	MCPWM_CH1P	PWM Channel 1 High Side
30	P1_7	P1.7
	MCPWM_CH1N	PWM Channel 1 Low Side
31	P1_8	P1.8



	MCPWM_CH2P	PWM Channel 2 High Side
32	P1_9	P1.9
	MCPWM_CH2N	PWM Channel 2 Low Side
33	P1_10	P1.10
	MCPWM_CH3P	PWM Channel 3 High-Side
	UART0_RXD	Serial port 0 receive (send)
	SCL	I2C clock
	TIM0_CH0	Timer0 channel 0
	ADC_TRIGGER0	ADC0 trigger signal output (for debugging)
	ADC0_CH13	ADC0 Channel 13
	EXTI12	External GPIO Interrupt Signal 12
34	PU	Built-in 12kΩ pull-up resistor; software switchable
	P1_11	P1.11
	MCPWM_CH3N	PWM Channel 3 Low Side
	UART0_TXD	Serial port 0 send (receive)
	SDA	I2C data
	TIM0_CH1	Timer0 channel 1
	ADC_TRIGGER1	ADC1 trigger signal output (for debugging)
	SIF	Single line communication
35	CLUOUT2	CLU2 output
	PU	Built-in 12kΩ pull-up resistor; software switchable
	P3_10	P3.10
36	MCPWM_CH4P	PWM Channel 4 High Side
	OPA2_IP	Positive input of operational amplifier 2
37	P3_11	P3.11
	MCPWM_CH4N	PWM Channel 4 Low Side
	OPA2_IN	Op Amp 2 Negative Input
38	P2_9	P2.9
	MCPWM_CH5P	PWM Channel 5 High Side
	SPI_DI	SPI Data In (Out)
	SCL	I2C clock
	CMP0_IP0	Comparator 0 positive input 0
	ADC0_CH12	ADC0 channel 12
	PU	Built-in 12kΩ pull-up resistor; software switchable
39	P2_10	P2.10
	MCPWM_CH5N	PWM Channel 5 Low Side
	SPI_DO	SPI Data Output (Input)
	SDA	I2C data
	PU	Built-in 12kΩ pull-up resistor; software switchable
40	P3_14	P3.14
	OPA3_IN	Op Amp 3 Negative Input
40	P3_15	P3.15
	OPA3_IP	Positive input of operational amplifier 3



41	P2_1	P2.1
	SPI_CLK	SPI clock
	ADC1_CH10	ADC1 Channel 10
	CMP1_IP0	Positive input 0 of comparator 1
42	P2_2	P2.2
	QEP1_Z	Phase Z of QEP1 encoder
	CMP1_IN	Comparator 1 Negative Input
43	P2_3	P2.3
	CMP1_OUT	Comparator 1 Output
	MCPWM_BKIN0	PWM shutdown input signal 0
	SPI_CS	SPI chip select
	TIM0_CH1	Timer0 channel 1
	QEP0_Z	QEP0 Encoder Phase Z
	CLUOUT3	CLU3 output
	FLT	IO filtering
	EXTI13	External GPIO Interrupt Signal 13
44	P2_4	P2.4
	CMP0_OUT	Comparator 0 Output
	HALL_IN0	HALL interface input 0
	MCPWM_CH2P	PWM Channel 2 High Side
	UART1_RXD	Serial port 1 receive (send)
	SPI_CLK	SPI clock
	TIM1_CH0	Timer1 channel 0
	TIM2_CH0	Timer2 channel 0
	ADC_TRIGGER0	ADC0 trigger signal output (for debugging)
	CMP1_IP1	Comparator 1 positive input 1
	FLT	IO filtering
	EXTI14	External GPIO Interrupt Signal 14
	WK5	External wake-up signal 5
PU	Built-in 12kΩ pull-up resistor, software switchable	
45	P2_5	P2.5
	CMP1_OUT	Comparator 1 Output
	HALL_IN1	HALL interface input 1
	MCPWM_CH2N	PWM Channel 2 Low Side
	UART1_TXD	Serial port 1 send (receive)
	SPI_DO	SPI Data Output (Input)
	TIM1_CH1	Timer1 channel 1
	TIM2_CH1	Timer2 channel 1
	ADC_TRIGGER1	ADC1 trigger signal output (for debugging)
	CMP1_IP2	Comparator 1 positive input 2
	FLT	IO filtering
PU	Built-in 12kΩ pull-up resistor, software switchable	
46	P2_6	P2.6



	CMP2_OUT	Comparator 2 Output
	HALL_IN2	HALL interface input 2
	MCPWM_CH3P	PWM Channel 3 High-Side
	TIM0_BKIN	TIMER0 _ FAIL signal from GPIO
	TIM3_CH0	Timer3 channel 0
	ADC_TRIGGER0	ADC0 trigger signal output (for debugging)
	SIF	Single line communication
	CLUOUT0	CLU0 output
	CMP1_IP3	Comparator 1 positive input 3
	FLT	IO filtering
	PU	Built-in 12kΩ pull-up resistor, software switchable
47	P2_14	P2.14
	SWCLK	SWD clock
	SPI_DI	SPI Data In (Out)
	SCL	I2C clock
	PU	Built-in 12kΩ pull-up resistor, software switchable
48	P2_15	P2.15
	SWDIO	SWD data
	UART0_RXD	Serial port 0 receive (send)
	SPI_CS	SPI chip select
	SDA	I2C data
	TIM2_CH1	Timer2 channel 1
	CLUOUT1	CLU1 output
	EXTI15	External GPIO Interrupt 15
	WK7	External wake-up signal 7
	PU	Built-in 12kΩ pull-up resistor, software switchable

3.1.3 LKS32MC071CBT8



Fig.3-3 LKS32MC071CBT8 Pin Assignment

\* The red PIN pin in the figure has a built-in resistor that pulls up to AVDD: The RSTn has an internal 300 kΩ pull-up resistor and is fixed on pull-up SWDIO/SWCLK has a 12kΩ internal pull-up resistor and is fixed on pull-up. The remaining red PIN pins have built-in 12 kΩ pull-up resistors, which can be turned on and off by software control.

Table3-3 LKS32MC071CBT8 Pin Function Description

1	P0_0	P0.0
	CLK0	Clock output (for debugging)
	MCPWM_BKIN0	PWM shutdown input signal 0
	UART0_RXD	Serial port 0 receive (send)
	SPI_DI	SPI Data In (Out)
	CLUOUT0	CLU0 output
	ADC01_CH4	ADC 0/ADC1 Channel 4
	DAC0_OUT	DAC0 output
	DAC1_OUT	DAC1 Output
	FLT	IO filtering



	EXTI0	External GPIO Interrupt Signal 0
	WK0	External wake-up signal 0
	PU	Built-in 12kΩ pull-up resistor, software switchable
2	P0_2	P0.2
	CLUOUT1	CLU1 output
	RST_n	Reset pin, P0.2 used as RSTN by default. It is recommended to connect a 10 nF to 100 nF capacitor to ground and place a 12 K to 20 K pull-up resistor between RSTN and AVDD. If there is an external pull-up resistor, the capacitance of RSTN should be 100 nF. P0.2 can be switched as a GPIO, which turns off the 12 kΩ pull-up resistor.
	FLT	IO filtering
	EXTI2	External GPIO Interrupt Signal 2
	WK1	External wake-up signal 1
	PU	Built-in 12kΩ pull-up resistor, software switchable
3	GND	Chip ground. It is strongly recommended that multiple ground pins be grounded uniformly on the PCB.
4	AVDD	Chip power supply, power supply range 2.5 ~ 5.5V
5	P3_2	P3.2
	MCPWM_CH3P	PWM Channel 3 High-Side
	CLUOUT2	CLU2 output
6	P0_3	P0.3
	MCPWM_CH4P	PWM Channel 4 High Side
	SCL	I2C clock
	TIM2_CH0	Timer2 channel 0
	ADC01_CH7	ADC0/ADC1 Channel 7
	EXTI3	External GPIO Interrupt Signal 3
	PU	Built-in 12kΩ pull-up resistor, software switchable
7	P0_4	P0.4
	MCPWM_CH4N	PWM Channel 4 Low Side
	SDA	I2C data
	TIM2_CH1	Timer2 channel 1
	ADC01_CH8	ADC0/ADC1 Channel 8
	PU	Built-in 12kΩ pull-up resistor, software switchable
8	P0_5	P0.5
	HALL_IN0	HALL interface input 0
	MCPWM_CH5P	PWM Channel 5 High Side
	QEPO_Z	QEPO Encoder Phase Z
	ADC01_CH9	ADC0/ADC1 Channel 9
9	P0_6	P0.6
	HALL_IN1	HALL interface input 1
	MCPWM_CH5N	PWM Channel 5 Low Side
	UART1_RXD	Serial port 1 receive (send)
	SCL	I2C clock



	TIM1_CH0	Timer1 channel 0
	CAN_RX	CAN receive
	CMP2_IN	Comparator 2 Negative Terminal Input
	FLT	IO filtering
	EXTI4	External GPIO Interrupt 4
	WK2	External wake-up signal 2
	PU	Built-in 12kΩ pull-up resistor, software switchable
10	P0_7	P0.7
	HALL_IN2	HALL interface input 2
	MCPWM_BKIN1	PWM Shutdown Input Signal 1
	UART1_TXD	Serial port 1 send (receive)
	SDA	I2C data
	TIM1_CH1	Timer1 channel 1
	CAN_TX	Can sender
	CMP2_IP0	Positive input 0 of comparator 2
	FLT	IO filtering
	PU	Built-in 12kΩ pull-up resistor, software switchable
11	P2_11	P2.11
	MCPWM_CH1P	PWM Channel 1 High Side
	TIM2_CH0	Timer2 channel 0
	CMP2_IP1	Positive Input 1 of Comparator 2
12	P2_12	P2.12
	MCPWM_CH1N	PWM Channel 1 Low Side
	SPI_CS	SPI chip select
	TIM2_CH1	Timer2 channel 1
	ADC_TRIGGER0	ADC0 trigger signal output (for debugging)
	CLUOUT3	CLU3 output
EXTI6	External GPIO Interrupt 6	
13	P0_11	P0.11
	HALL_IN0	HALL interface input 0
	TIM3_CH0	Timer3 channel 0
	ADC1_CH11	ADC1 Channel 11
	CMP0_IP1	Comparator 0 positive input 1
	FLT	IO filtering
	EXTI7	External GPIO Interrupt Signal 7
WK3	External wake-up signal 3	
14	P0_12	P0.12
	HALL_IN1	HALL interface input 1
	TIM3_CH1	Timer3 channel 1
	ADC1_CH12	ADC1 Channel 12
	CAN_RX	CAN receive
	CMP0_IP2	Comparator 0 positive input 2
	FLT	IO filtering



15	P0_13	P0.13
	HALL_IN2	HALL interface input 2
	QEPO_Z	QEPO Encoder Phase Z
	ADC1_CH13	ADC1 Channel 13
	CAN_TX	CAN sender
	CMP0_IP3	Comparator 0 positive input 3
	FLT	IO filtering
16	P0_14	P0.14
	CMP0_OUT	Comparator 0 Output
	MCPWM_BKIN1	PWM Shutdown Input Signal 1
	UART0_TXD	Serial port 0 send (receive)
	SPI_CLK	SPI clock
	SCL	I2C clock
	TIM0_CH1	Timer0 channel 1
	QEP1_Z	Phase Z of QEP1 encoder
	ADC_TRIGGER0	ADC0 trigger signal output (for debugging)
	SIF	Single line communication
	CLUOUT0	CLU0 output
	ADC0_CH10	ADC0 Channel 10
	CMP0_IP4	Comparator 0 positive input 4
	FLT	IO filtering
	EXTI8	External GPIO Interrupt Signal 8
WK4	External wake-up signal 4	
PU	Built-in 12kΩ pull-up resistor, software switchable	
17	P0_15	P0.15
	CMP2_OUT	Comparator 2 Output
	MCPWM_CH0P	PWM Channel 0 High Side
	UART0_RXD	Serial port 0 receive (send)
	SPI_DO	SPI Data Output (Input)
	SDA	I2C data
	TIM0_CH0	Timer0 channel 0
	ADC_TRIGGER1	ADC1 trigger signal output (for debugging)
	CMP0_IN	Comparator 0 negative input
	FLT	IO filtering
	EXTI9	External GPIO Interrupt 9
	PU	Built-in 12kΩ pull-up resistor, software switchable
18	P1_0	P1.0
	MCPWM_CH0N	PWM Channel 0 Low Side
	UART0_TXD	Serial port 0 send (receive)
	SPI_DI	SPI Data In (Out)
	TIM0_BKIN	TIMER0 _ FAIL signal from GPIO
	EXTI10	External GPIO Interrupt Signal 10
	PU	Built-in 12kΩ pull-up resistor, software switchable



19	P1_3	P1.3
	TIM3_CH1	Timer3 channel 1
	ADC01_CH5	ADC 0/ADC1 Channel 5
	PU	Built-in 12kΩ pull-up resistor, software switchable
20	P3_5	P3.5
	OPA0_IP	Positive terminal input of operational amplifier 0
21	P3_7	P3.7
	OPA0_IN	Input of negative terminal of operational amplifier 0
22	P2_7	P2.7
	CLKO	Clock output (for debugging)
	UART0_TXD	Serial port 0 send (receive)
	TIM0_CH0	Timer0 channel 0
	TIM3_CH1	Timer3 channel 1
	ADC_TRIGGER1	ADC1 trigger signal output (for debugging)
	CAN_TX	CAN sender
	CLUOUT1	CLU1 output
	ADC0_CH11	ADC0 Channel 11
	OPAx_OUT	Op Amp Output
	LDO15	1.5V LDO Output
	REF	Reference Voltage
	EXTI11	External GPIO Interrupt Signal 11
	WK6	External wake-up signal 6
	PU	Built-in 12kΩ pull-up resistor, software switchable
23	P3_0	P3.0
	OPA1_IP	Positive input of operational amplifier 1
24	P3_1	P3.1
	OPA1_IN	Op Amp 1 Negative Input
25	P2_8	P2.8
	UART1_RXD	Serial port 1 receive (send)
	SPI_DO	SPI Data Output (Input)
	TIM3_CH0	Timer3 channel 0
	OSC_IN	External crystal pin
	PU	Built-in 12kΩ pull-up resistor, software switchable
26	P3_9	P3.9
	UART1_TXD	Serial port 1 send (receive)
	TIM3_CH1	Timer3 channel 1
	OSC_OUT	External crystal pin
	PU	Built-in 12kΩ pull-up resistor, software switchable
27	P1_4	P1.4
	MCPWM_CH0P	PWM Channel 0 High Side
	QEPO_Z	QEPO Encoder Phase Z
28	P1_5	P1.5
	MCPWM_CH0N	PWM Channel 0 Low Side



29	P1_6	P1.6
	MCPWM_CH1P	PWM Channel 1 High Side
30	P1_7	P1.7
	MCPWM_CH1N	PWM Channel 1 Low Side
31	P1_8	P1.8
	MCPWM_CH2P	PWM Channel 2 High Side
32	P1_9	P1.9
	MCPWM_CH2N	PWM Channel 2 Low Side
33	P1_10	P1.10
	MCPWM_CH3P	PWM Channel 3 High-Side
	UART0_RXD	Serial port 0 receive (send)
	SCL	I2C clock
	TIM0_CH0	Timer0 channel 0
	ADC_TRIGGER0	ADC0 trigger signal output (for debugging)
	ADC0_CH13	ADC0 Channel 13
	EXTI12	External GPIO Interrupt Signal 12
34	PU	Built-in 12kΩ pull-up resistor, software switchable
	P1_11	P1.11
	MCPWM_CH3N	PWM Channel 3 Low Side
	UART0_TXD	Serial port 0 send (receive)
	SDA	I2C data
	TIM0_CH1	Timer0 channel 1
	ADC_TRIGGER1	ADC1 trigger signal output (for debugging)
	SIF	Single line communication
	CLUOUT2	CLU2 output
PU	Built-in 12kΩ pull-up resistor, software switchable	
35	P3_10	P3.10
	MCPWM_CH4P	PWM Channel 4 High Side
	OPA2_IP	Positive input of operational amplifier 2
36	P3_11	P3.11
	MCPWM_CH4N	PWM Channel 4 Low Side
	OPA2_IN	Op Amp 2 Negative Input
37	P2_9	P2.9
	MCPWM_CH5P	PWM Channel 5 High Side
	SPI_DI	SPI Data In (Out)
	SCL	I2C clock
	CMP0_IP0	Comparator 0 positive input 0
	ADC0_CH12	ADC0 channel 12
38	PU	Built-in 12kΩ pull-up resistor, software switchable
	P2_10	P2.10
	MCPWM_CH5N	PWM Channel 5 Low Side
	SPI_DO	SPI Data Output (Input)
	SDA	I2C data



	PU	Built-in 12kΩ pull-up resistor, software switchable
39	P3_14	P3.14
	OPA3_IN	Op Amp 3 Negative Input
40	P3_15	P3.15
	OPA3_IP	Positive input of operational amplifier 3
41	P2_1	P2.1
	SPI_CLK	SPI clock
	ADC1_CH10	ADC1 Channel 10
	CMP1_IP0	Positive input 0 of comparator 1
42	P2_2	P2.2
	QEP1_Z	Phase Z of QEP1 encoder
	CMP1_IN	Comparator 1 Negative Input
43	P2_3	P2.3
	CMP1_OUT	Comparator 1 Output
	MCPWM_BKIN0	PWM shutdown input signal 0
	SPI_CS	SPI chip select
	TIM0_CH1	Timer0 channel 1
	QEP0_Z	QEP0 Encoder Phase Z
	CLUOUT3	CLU3 output
	FLT	IO filtering
EXTI13	External GPIO Interrupt Signal 13	
44	P2_4	P2.4
	CMP0_OUT	Comparator 0 Output
	HALL_IN0	HALL interface input 0
	MCPWM_CH2P	PWM Channel 2 High Side
	UART1_RXD	Serial port 1 receive (send)
	SPI_CLK	SPI clock
	TIM1_CH0	Timer1 channel 0
	TIM2_CH0	Timer2 channel 0
	ADC_TRIGGER0	ADC0 trigger signal output (for debugging)
	CAN_RX	CAN receive
	CMP1_IP1	Comparator 1 positive input 1
	FLT	IO filtering
	EXTI14	External GPIO Interrupt Signal 14
	WK5	External wake-up signal 5
PU	Built-in 12kΩ pull-up resistor, software switchable	
45	P2_5	P2.5
	CMP1_OUT	Comparator 1 Output
	HALL_IN1	HALL interface input 1
	MCPWM_CH2N	PWM Channel 2 Low Side
	UART1_TXD	Serial port 1 send (receive)
	SPI_DO	SPI Data Output (Input)
	TIM1_CH1	Timer1 channel 1



	TIM2_CH1	Timer2 channel 1
	ADC_TRIGGER1	ADC1 trigger signal output (for debugging)
	CAN_TX	CAN sender
	CMP1_IP2	Comparator 1 positive input 2
	FLT	IO filtering
	PU	Built-in 12kΩ pull-up resistor; software switchable
46	P2_6	P2.6
	CMP2_OUT	Comparator 2 Output
	HALL_IN2	HALL interface input 2
	MCPWM_CH3P	PWM Channel 3 High-Side
	TIM0_BKIN	TIMER0 _ FAIL signal from GPIO
	TIM3_CH0	Timer3 channel 0
	ADC_TRIGGER0	ADC0 trigger signal output (for debugging)
	SIF	Single line communication
	CLUOUT0	CLU0 output
	CMP1_IP3	Comparator 1 positive input 3
	FLT	IO filtering
	PU	Built-in 12kΩ pull-up resistor; software switchable
47	P2_14	P2.14
	SWCLK	SWD clock
	SPI_DI	SPI Data In (Out)
	SCL	I2C clock
	PU	Built-in 12kΩ pull-up resistor; software switchable
48	P2_15	P2.15
	SWDIO	SWD data
	UART0_RXD	Serial port 0 receive (send)
	SPI_CS	SPI chip select
	SDA	I2C data
	TIM2_CH1	Timer2 channel 1
	CLUOUT1	CLU1 output
	EXTI15	External GPIO Interrupt 15
	WK7	External wake-up signal 7
	PU	Built-in 12kΩ pull-up resistor; software switchable

3.1.4 LKS32MC072KBQ8

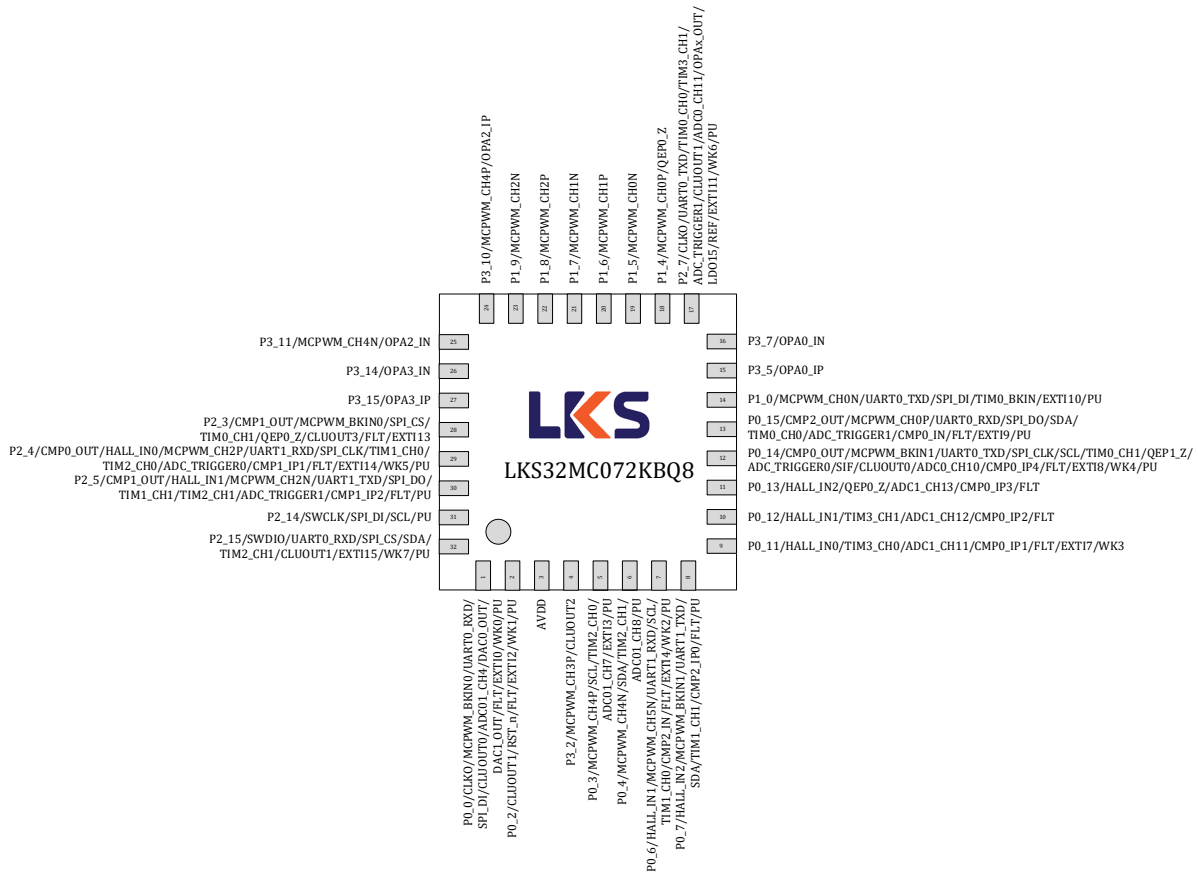

Fig 3-4 LKS32MC072KBQ8 Pin Assignment

\* The red PIN pin in the figure has a built-in resistor that pulls up to AVDD: The RSTN has an internal 300 kΩ pull-up resistor and is fixed on pull-up SWDIO/SWCLK has a 12kΩ internal pull-up resistor and is fixed on pull-up. The remaining red PIN pins have built-in 12 kΩ pull-up resistors, which can be turned on and off by software control.

Table 3-4 LKS32MC072KBQ8 Pin Function Description

0	GND	In the heat dissipation area of the abdomen, Pad is the chip GND
1	P0_0	P0.0
	CLKO	Clock output (for debugging)
	MCPWM_BKIN0	PWM shutdown input signal 0
	UART0_RXD	Serial port 0 receive (send)
	SPI_DI	SPI Data In (Out)
	CLUOUT0	CLU0 output
	ADC01_CH4	ADC 0/ADC1 Channel 4
	DAC0_OUT	DAC0 output
	DAC1_OUT	DAC1 Output
	FLT	IO filtering



	EXTI0	External GPIO Interrupt Signal 0
	WK0	External wake-up signal 0
	PU	Built-in 12kΩ pull-up resistor, software switchable
2	P0_2	P0.2
	CLUOUT1	CLU1 output
	RST_n	Reset pin, P0.2 used as RSTN by default. It is recommended to connect a 10 nF to 100 nF capacitor to ground and place a 12 K to 20 K pull-up resistor between RSTN and AVDD. If there is an external pull-up resistor, the capacitance of RSTN should be 100 nF. P0.2 can be switched as a GPIO, which turns off the 12 kΩ pull-up resistor.
	FLT	IO filtering
	EXTI2	External GPIO Interrupt Signal 2
	WK1	External wake-up signal 1
	PU	Built-in 12kΩ pull-up resistor, software switchable
3	AVDD	Chip power supply, power supply range 2.5 ~ 5.5V
4	P3_2	P3.2
	MCPWM_CH3P	PWM Channel 3 High-Side
	CLUOUT2	CLU2 output
5	P0_3	P0.3
	MCPWM_CH4P	PWM Channel 4 High Side
	SCL	I2C clock
	TIM2_CH0	Timer2 channel 0
	ADC01_CH7	ADC0/ADC1 Channel 7
	EXTI3	External GPIO Interrupt Signal 3
PU	Built-in 12kΩ pull-up resistor, software switchable	
6	P0_4	P0.4
	MCPWM_CH4N	PWM Channel 4 Low Side
	SDA	I2C data
	TIM2_CH1	Timer2 channel 1
	ADC01_CH8	ADC0/ADC1 Channel 8
	PU	Built-in 12kΩ pull-up resistor, software switchable
7	P0_6	P0.6
	HALL_IN1	HALL interface input 1
	MCPWM_CH5N	PWM Channel 5 Low Side
	UART1_RXD	Serial port 1 receive (send)
	SCL	I2C clock
	TIM1_CH0	Timer1 channel 0
	CMP2_IN	Comparator 2 Negative Terminal Input
	FLT	IO filtering
	EXTI4	External GPIO Interrupt 4
	WK2	External wake-up signal 2
PU	Built-in 12kΩ pull-up resistor, software switchable	
8	P0_7	P0.7

	HALL_IN2	HALL interface input 2
	MCPWM_BKIN1	PWM Shutdown Input Signal 1
	UART1_TXD	Serial port 1 send (receive)
	SDA	I2C data
	TIM1_CH1	Timer1 channel 1
	CMP2_IP0	Positive input 0 of comparator 2
	FLT	IO filtering
	PU	Built-in 12kΩ pull-up resistor, software switchable
9	P0_11	P0.11
	HALL_IN0	HALL interface input 0
	TIM3_CH0	Timer3 channel 0
	ADC1_CH11	ADC1 Channel 11
	CMP0_IP1	Comparator 0 positive input 1
	FLT	IO filtering
	EXTI7	External GPIO Interrupt Signal 7
10	WK3	External wake-up signal 3
	P0_12	P0.12
	HALL_IN1	HALL interface input 1
	TIM3_CH1	Timer3 channel 1
	ADC1_CH12	ADC1 Channel 12
	CMP0_IP2	Comparator 0 positive input 2
11	FLT	IO filtering
	P0_13	P0.13
	HALL_IN2	HALL interface input 2
	QEP0_Z	QEP0 Encoder Phase Z
	ADC1_CH13	ADC1 Channel 13
	CMP0_IP3	Comparator 0 positive input 3
12	FLT	IO filtering
	P0_14	P0.14
	CMP0_OUT	Comparator 0 Output
	MCPWM_BKIN1	PWM Shutdown Input Signal 1
	UART0_TXD	Serial port 0 send (receive)
	SPI_CLK	SPI clock
	SCL	I2C clock
	TIM0_CH1	Timer0 channel 1
	QEP1_Z	Phase Z of QEP1 encoder
	ADC_TRIGGER0	ADC0 trigger signal output (for debugging)
	SIF	Single line communication
	CLUOUT0	CLU0 output
	ADC0_CH10	ADC0 Channel 10
	CMP0_IP4	Comparator 0 positive input 4
FLT	IO filtering	
EXTI8	External GPIO Interrupt Signal 8	



	WK4	External wake-up signal 4
	PU	Built-in 12kΩ pull-up resistor, software switchable
13	P0_15	P0.15
	CMP2_OUT	Comparator 2 Output
	MCPWM_CH0P	PWM Channel 0 High Side
	UART0_RXD	Serial port 0 receive (send)
	SPI_DO	SPI Data Output (Input)
	SDA	I2C data
	TIM0_CH0	Timer0 channel 0
	ADC_TRIGGER1	ADC1 trigger signal output (for debugging)
	CMP0_IN	Comparator 0 negative input
	FLT	IO filtering
	EXTI9	External GPIO Interrupt 9
	PU	Built-in 12kΩ pull-up resistor, software switchable
	14	P1_0
MCPWM_CH0N		PWM Channel 0 Low Side
UART0_TXD		Serial port 0 send (receive)
SPI_DI		SPI Data In (Out)
TIM0_BKIN		TIMERO _ FAIL signal from GPIO
EXTI10		External GPIO Interrupt Signal 10
PU		Built-in 12kΩ pull-up resistor, software switchable
15	P3_5	P3.5
	OPA0_IP	Positive terminal input of operational amplifier 0
16	P3_7	P3.7
	OPA0_IN	Input of negative terminal of operational amplifier 0
17	P2_7	P2.7
	CLKO	Clock output (for debugging)
	UART0_TXD	Serial port 0 send (receive)
	TIM0_CH0	Timer0 channel 0
	TIM3_CH1	Timer3 channel 1
	ADC_TRIGGER1	ADC1 trigger signal output (for debugging)
	CLUOUT1	CLU1 output
	ADC0_CH11	ADC0 Channel 11
	OPAx_OUT	Op Amp Output
	LDO15	1.5V LDO Output
	REF	Reference Voltage
	EXTI11	External GPIO Interrupt Signal 11
	WK6	External wake-up signal 6
PU	Built-in 12kΩ pull-up resistor, software switchable	
18	P1_4	P1.4
	MCPWM_CH0P	PWM Channel 0 High Side
	QEPO_Z	QEPO Encoder Phase Z
19	P1_5	P1.5



	MCPWM_CH0N	PWM Channel 0 Low Side
20	P1_6	P1.6
	MCPWM_CH1P	PWM Channel 1 High Side
21	P1_7	P1.7
	MCPWM_CH1N	PWM Channel 1 Low Side
22	P1_8	P1.8
	MCPWM_CH2P	PWM Channel 2 High Side
23	P1_9	P1.9
	MCPWM_CH2N	PWM Channel 2 Low Side
24	P3_10	P3.10
	MCPWM_CH4P	PWM Channel 4 High Side
	OPA2_IP	Positive input of operational amplifier 2
25	P3_11	P3.11
	MCPWM_CH4N	PWM Channel 4 Low Side
	OPA2_IN	Op Amp 2 Negative Input
26	P3_14	P3.14
	OPA3_IN	Op Amp 3 Negative Input
27	P3_15	P3.15
	OPA3_IP	Positive input of operational amplifier 3
28	P2_3	P2.3
	CMP1_OUT	Comparator 1 Output
	MCPWM_BKIN0	PWM shutdown input signal 0
	SPI_CS	SPI chip select
	TIM0_CH1	Timer0 channel 1
	QEPO_Z	QEPO Encoder Phase Z
	CLUOUT3	CLU3 output
	FLT	IO filtering
EXTI13	External GPIO Interrupt Signal 13	
29	P2_4	P2.4
	CMP0_OUT	Comparator 0 Output
	HALL_IN0	HALL interface input 0
	MCPWM_CH2P	PWM Channel 2 High Side
	UART1_RXD	Serial port 1 receive (send)
	SPI_CLK	SPI clock
	TIM1_CH0	Timer1 channel 0
	TIM2_CH0	Timer2 channel 0
	ADC_TRIGGER0	ADC0 trigger signal output (for debugging)
	CMP1_IP1	Comparator 1 positive input 1
	FLT	IO filtering
	EXTI14	External GPIO Interrupt Signal 14
	WK5	External wake-up signal 5
PU	Built-in 12kΩ pull-up resistor, software switchable	
30	P2_5	P2.5



	CMP1_OUT	Comparator 1 Output
	HALL_IN1	HALL interface input 1
	MCPWM_CH2N	PWM Channel 2 Low Side
	UART1_TXD	Serial port 1 send (receive)
	SPI_DO	SPI Data Output (Input)
	TIM1_CH1	Timer1 channel 1
	TIM2_CH1	Timer2 channel 1
	ADC_TRIGGER1	ADC1 trigger signal output (for debugging)
	CMP1_IP2	Comparator 1 positive input 2
	FLT	IO filtering
	PU	Built-in 12kΩ pull-up resistor, software switchable
31	P2_14	P2.14
	SWCLK	SWD clock
	SPI_DI	SPI Data In (Out)
	SCL	I2C clock
	PU	Built-in 12kΩ pull-up resistor, software switchable
32	P2_15	P2.15
	SWDIO	SWD data
	UART0_RXD	Serial port 0 receive (send)
	SPI_CS	SPI chip select
	SDA	I2C data
	TIM2_CH1	Timer2 channel 1
	CLUOUT1	CLU1 output
	EXTI15	External GPIO Interrupt 15
	WK7	External wake-up signal 7
	PU	Built-in 12kΩ pull-up resistor, software switchable

3.1.5 LKS32MC072KBT8

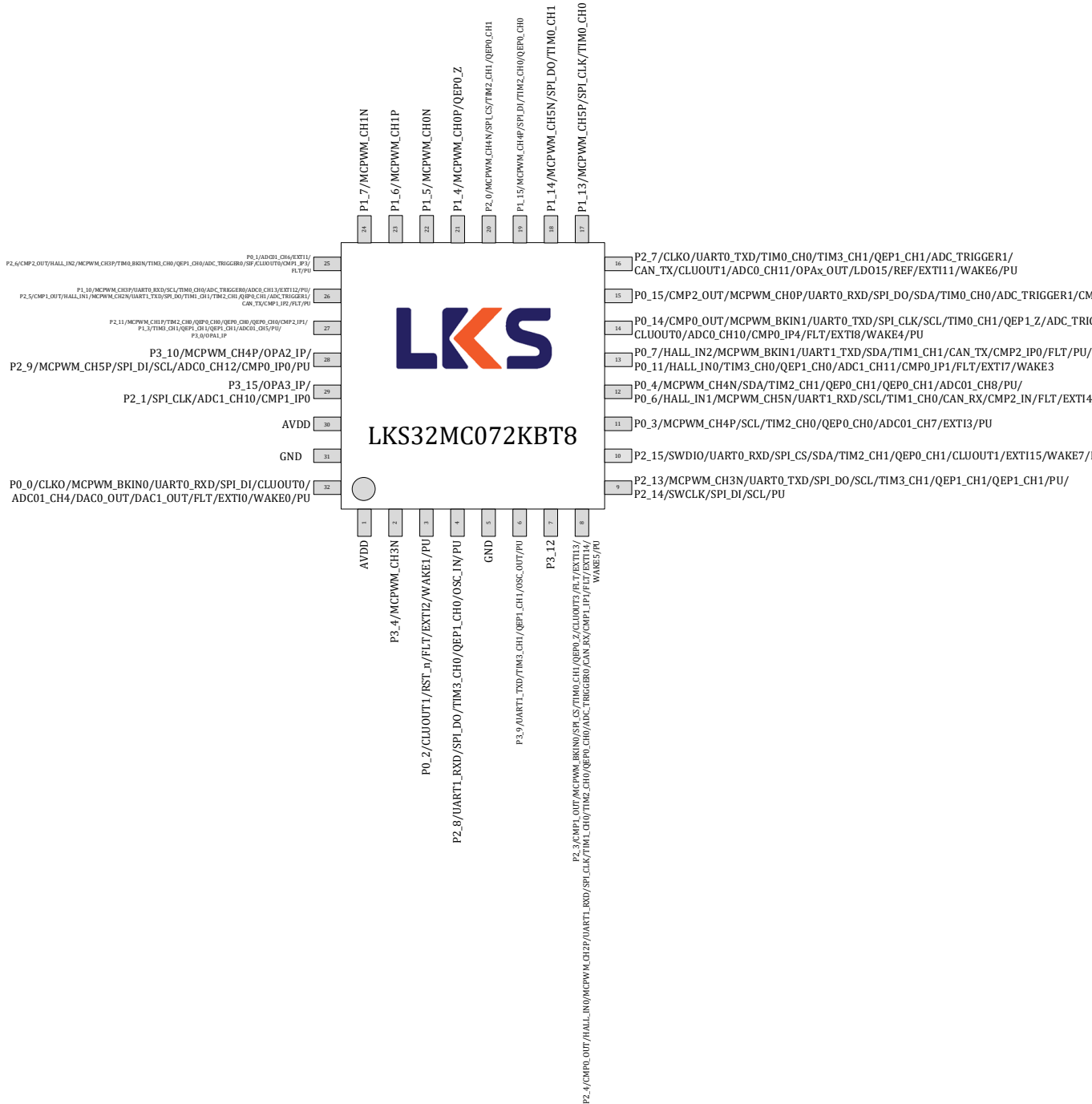

Fig.3-5 LKS32MC072KBT8 Pin Assignment

Note:

To be compatible with RX13T, the MCPWM output sequence and GPIO corresponding sequence of 072KBT8 are different from other 07x series MCU. Need to configure PWM\_SWAP=2 to account for



this difference.

Table 3-5 LKS32MC072KBT8 Pin Function Description

1	AVDD	Chip power supply, power supply range 2.5 ~ 5.5V
2	P3_4	P3.4
	MCPWM_CH3N	PWM channel 3 low-side
3	P0_2	P0.2
	CLUOUT1	CLU1 output
	RST_n	P0.2 is used as RSTN by default. A 10nF-100nF capacitor should be connected to the ground. It is recommended a 12k-20k pull-up resistor is placed between RSTN and AVDD on PCB. If there is an external pull-up resistor, the capacitance of RSTN should be 100nF. The built-in 12kΩ pull-up resistor could be turned-off by software.
	FLT	IO filter
	EXTI2	External GPIO interrupt input signal 2
	WAKE1	External wake-up signal 1
	PU	Built-in 12kΩ Pull-up resistor which could be turn-off by software
4	P2_8	P2.8
	UART1_RXD	UART1 receive(transmit)
	SPI_DO	SPI data output(input)
	TIM3_CH0	Timer3 channel0
	QEP1_CH0	Encoder1 channel0
	OSC_IN	External crystal oscillator pin
	PU	Built-in 12kΩ Pull-up resistor which could be turn-off by software
5	GND	GND
6	P3_9	P3.9
	UART1_TXD	UART1 transmit(receive)
	TIM3_CH1	Timer3 channel1
	QEP1_CH1	Encoder1 channel1
	OSC_OUT	External crystal oscillator pin
	PU	Built-in 12kΩ Pull-up resistor which could be turn-off by software
7	P3_12	P3.12
8	P2_3	P2.3
	CMP1_OUT	Comparator 1 output
	MCPWM_BKIN0	PWM break signal 0
	SPI_CS	SPI chip select
	TIM0_CH1	Timer0 channel1
	QEP0_Z	QEP0 encoder Z phase
	CLUOUT3	CLU3 output
	FLT	IO filter
	EXTI13	External GPIO interrupt input signal 13
	P2_4	P2.4
CMP0_OUT	Comparator 0 output	



	HALL_IN0	Hall interface input 0
	MCPWM_CH5N	PWM channel 5 low-side
	UART1_RXD	UART1 receive(transmit)
	SPI_CLK	SPI clock
	TIM1_CH0	Timer1 channel0
	TIM2_CH0	Timer2 channel0
	QEP0_CH0	Encoder0 channel0
	ADC_TRIGGER0	ADC0 trigger for debug
	CAN_RX	CAN Receive
	CMP1_IP1	Comparator1 positive input1
	FLT	IO filter
	EXTI14	External GPIO interrupt input signal 14
	WAKE5	External wake-up signal 5
	PU	Built-in 12kΩ Pull-up resistor which could be turn-off by software
9	P2_13	P2.13
	MCPWM_CH5P	PWM channel 5 high-side
	UART0_TXD	UART0 transmit(receive)
	SPI_DO	SPI data output(input)
	SCL	I2C clock
	TIM3_CH1	Timer3 channel1
	QEP1_CH1	Encoder1 channel1
	QEP1_CH1	Encoder1 channel1
	PU	Built-in 12kΩ Pull-up resistor which could be turn-off by software
	P2_14	P2.14
	SWCLK	SWD Clock
	SPI_DI	SPI data input(output)
	SCL	I2C clock
	PU	Built-in 12kΩ Pull-up resistor which could be turn-off by software
10	P2_15	P2.15
	SWDIO	SWD Data
	UART0_RXD	UART0 receive(transmit)
	SPI_CS	SPI chip select
	SDA	I2C data
	TIM2_CH1	Timer2 channel1
	QEP0_CH1	Encoder0 channel1
	CLUOUT1	CLU1 output
	EXTI15	External GPIO interrupt input signal 15
	WAKE7	External wake-up signal 7
	PU	Built-in 12kΩ Pull-up resistor which could be turn-off by software
11	P0_3	P0.3
	MCPWM_CH2N	PWM channel 2 low-side
	SCL	I2C clock
	TIM2_CH0	Timer2 channel0



	QEPO_CH0	Encoder0 channel0
	ADC01_CH7	ADC01 channel 7
	EXTI3	External GPIO interrupt input signal 3
	PU	Built-in 12kΩ Pull-up resistor which could be turn-off by software
12	P0_4	P0.4
	MCPWM_CH0P	PWM channel 0 high-side
	SDA	I2C data
	TIM2_CH1	Timer2 channel1
	QEPO_CH1	Encoder0 channel1
	QEPO_CH1	Encoder0 channel1
	ADC01_CH8	ADC01 channel 8
	PU	Built-in 12kΩ Pull-up resistor which could be turn-off by software
	P0_6	P0.6
	HALL_IN1	Hall interface input 1
	MCPWM_CH1N	PWM channel 1 low-side
	UART1_RXD	UART1 receive(transmit)
	SCL	I2C clock
	TIM1_CH0	Timer1 channel0
	CAN_RX	CAN Receive
	CMP2_IN	Comparator2 negative input
	FLT	IO filter
	EXTI4	External GPIO interrupt input signal 4
	WAKE2	External wake-up signal 2
	PU	Built-in 12kΩ Pull-up resistor which could be turn-off by software
13	P0_7	P0.7
	HALL_IN2	Hall interface input 2
	MCPWM_BKIN1	PWM break signal 1
	UART1_TXD	UART1 transmit(receive)
	SDA	I2C data
	TIM1_CH1	Timer1 channel1
	CAN_TX	CAN Transmit
	CMP2_IP0	Comparator2 positive input0
	FLT	IO filter
	PU	Built-in 12kΩ Pull-up resistor which could be turn-off by software
	P0_11	P0.11
	HALL_IN0	Hall interface input 0
	TIM3_CH0	Timer3 channel0
	QEP1_CH0	Encoder1 channel0
	ADC1_CH11	ADC1 channel 11
	CMP0_IP1	Comparator0 positive input1
	FLT	IO filter
	EXTI7	External GPIO interrupt input signal 7
WAKE3	External wake-up signal 3	



14	P0_14	P0.14
	CMP0_OUT	Comparator 0 output
	MCPWM_BKIN1	PWM break signal 1
	UART0_TXD	UART0 transmit(receive)
	SPI_CLK	SPI clock
	SCL	I2C clock
	TIM0_CH1	Timer0 channel1
	QEP1_Z	QEP1 encoder Z phase
	ADC_TRIGGER0	ADC0 trigger for debug
	SIF	Single line communication
	CLUOUT0	CLU0 output
	ADC0_CH10	ADC0 channel 10
	CMP0_IP4	Comparator0 positive input4
	FLT	IO filter
	EXTI8	External GPIO interrupt input signal 8
	WAKE4	External wake-up signal 4
	PU	Built-in 12kΩ Pull-up resistor which could be turn-off by software
15	P0_15	P0.15
	CMP2_OUT	Comparator 2 output
	MCPWM_CH1P	PWM channel 1 high-side
	UART0_RXD	UART0 receive(transmit)
	SPI_DO	SPI data output(input)
	SDA	I2C data
	TIM0_CH0	Timer0 channel0
	ADC_TRIGGER1	ADC1 trigger for debug
	CMP0_IN	Comparator0 negative input
	FLT	IO filter
	EXTI9	External GPIO interrupt input signal 9
	PU	Built-in 12kΩ Pull-up resistor which could be turn-off by software
16	P2_7	P2.7
	CLK0	Clock output for debug
	UART0_TXD	UART0 transmit(receive)
	TIM0_CH0	Timer0 channel0
	TIM3_CH1	Timer3 channel1
	QEP1_CH1	Encoder1 channel1
	ADC_TRIGGER1	ADC1 trigger for debug
	CAN_TX	CAN Transmit
	CLUOUT1	CLU1 output
	ADC0_CH11	ADC0 channel 11
	OPA <sub>x</sub> _OUT	OPA output
	LDO15	1.5V LDO output
	REF	Reference voltage output for debug
	EXTI11	External GPIO interrupt input signal 11



	WAKE6	External wake-up signal 6
	PU	Built-in 12kΩ Pull-up resistor which could be turn-off by software
17	P1_13	P1.13
	MCPWM_CH0N	PWM channel 0 low-side
	SPI_CLK	SPI clock
	TIM0_CH0	Timer0 channel0
18	P1_14	P1.14
	MCPWM_CH1N	PWM channel 1 low-side
	SPI_DO	SPI data output(input)
	TIM0_CH1	Timer0 channel1
19	P1_15	P1.15
	MCPWM_CH2N	PWM channel 2 low-side
	SPI_DI	SPI data input(output)
	TIM2_CH0	Timer2 channel0
	QEP0_CH0	Encoder0 channel0
20	P2_0	P2.0
	MCPWM_CH0P	PWM channel 0 high-side
	SPI_CS	SPI chip select
	TIM2_CH1	Timer2 channel1
	QEP0_CH1	Encoder0 channel1
21	P1_4	P1.4
	MCPWM_CH1P	PWM channel 1 high-side
	QEP0_Z	QEP0 encoder Z phase
22	P1_5	P1.5
	MCPWM_CH2P	PWM channel 2 high-side
23	P1_6	P1.6
	MCPWM_CH3N	PWM channel 3 low-side
24	P1_7	P1.7
	MCPWM_CH4N	PWM channel 4 low-side
25	P0_1	P0.1
	ADC01_CH6	PWM channel 5 low-side
	EXTI1	External GPIO interrupt input signal 1
	P2_6	P2.6
	CMP2_OUT	Comparator 2 Output
	HALL_IN2	Hall interface input 2
	MCPWM_CH3P	PWM channel 4 high-side
	TIM0_BKIN	TIMER0 _ FAIL signal from GPIO
	TIM3_CH0	Timer3 channel0
	QEP1_CH0	Encoder1 channel0
	ADC_TRIGGER0	ADC0 trigger for debug
	SIF	Single line communication
	CLUOUT0	CLU0 output
	CMP1_IP3	Comparator 1 positive input 3



	FLT	IO filter
	PU	Built-in 12kΩ Pull-up resistor which could be turn-off by software
26	P1_10	P1.10
	MCPWM_CH3P	PWM channel 4 high-side
	UART0_RXD	UART0 receive(transmit)
	SCL	I2C clock
	TIM0_CH0	Timer0 channel0
	ADC_TRIGGER0	ADC0 trigger for debug
	ADC0_CH13	ADC0 channel 13
	EXTI12	External GPIO interrupt input signal 12
	PU	Built-in 12kΩ Pull-up resistor which could be turn-off by software
	P2_5	P2.5
10	CMP1_OUT	Comparator 1 Output
	HALL_IN1	Hall interface input 1
	MCPWM_CH2N	PWM channel 2 low-side
	UART1_TXD	UART1 transmit(receive)
	SPI_DO	SPI Data Output (Input)
	TIM1_CH1	Timer1 channel1
	TIM2_CH1	Timer2 channel1
	QEP0_CH1	Encoder0 channel1
	ADC_TRIGGER1	ADC1 trigger for debug
	CAN_TX	CAN Transmit
27	CMP1_IP2	Comparator 1 positive input 2
	FLT	IO filter
28	PU	Built-in 12kΩ Pull-up resistor which could be turn-off by software
	P3_0	P3.0
	OPA1_IP	OPA1 positive input
	P3_10	P3.10
	MCPWM_CH2N	PWM channel 2 low-side
	OPA2_IP	OPA2 positive input
	P2_9	P2.9
	MCPWM_CH0N	PWM channel 0 low-side
	SPI_DI	SPI data input(output)
	SCL	I2C clock
29	ADC0_CH12	ADC0 channel 12
	CMP0_IP0	Comparator0 positive input0
	PU	Built-in 12kΩ Pull-up resistor which could be turn-off by software
	P3_15	P3.15
	OPA3_IP	OPA3 positive input
	P2_1	P2.1
29	SPI_CLK	SPI clock
	ADC1_CH10	ADC1 channel 10
	CMP1_IP0	Comparator1 positive input0



30	AVDD	Power supply, 2.2~5.5V
31	GND	Ground
32	P0_0	P0.0
	CLKO	Clock output for debug
	MCPWM_BKIN0	PWM break signal 0
	UART0_RXD	UART0 receive(transmit)
	SPI_DI	SPI data input(output)
	CLUOUT0	CLU0 output
	ADC01_CH4	ADC01 channel 4
	DAC0_OUT	DAC0 out put
	DAC1_OUT	DAC1 out put
	FLT	IO filter
	EXTI0	External GPIO interrupt input signal 0
	WAKE0	External wake-up signal 0
	PU	Built-in 12kΩ Pull-up resistor which could be turn-off by software

3.1.6 LKS32MC073HBQ8

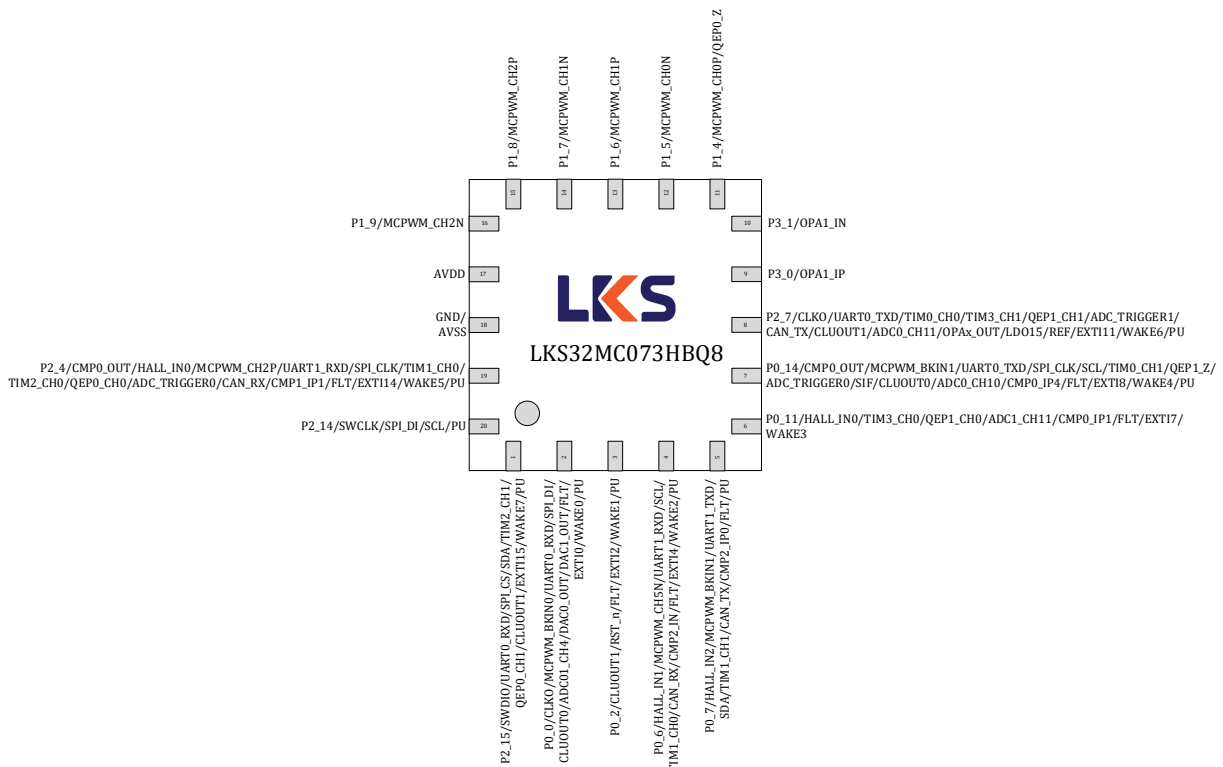

Fig.3-6 LKS32MC073HBQ8 Pin Assignment

The RSTN has an internal 300 kΩ pull-up resistor and is fixed on pull-up  
 SWDIO/SWCLK has a 12kΩ internal pull-up resistor and is fixed on pull-up.



Table 3-6 LKS32MC073HBQ8 Pin Function Description

0	GND	In the heat dissipation area of the abdomen, Pad is the chip GND
1	P2_15	P2.15
	SWDIO	SWD Data
	UART0_RXD	UART0 receive(transmit)
	SPI_CS	SPI chip select
	SDA	I2C data
	TIM2_CH1	Timer2 channel1
	QEPO_CH1	Encoder0 channel1
	CLUOUT1	CLU1 output
	EXTI15	External GPIO interrupt input signal 15
	WAKE7	External wake-up signal 7
	PU	Built-in 12kΩ Pull-up resistor which could be turn-off by software
2	P0_0	P0.0
	CLK0	Clock output for debug
	MCPWM_BKIN0	PWM break signal 0
	UART0_RXD	UART0 receive(transmit)
	SPI_DI	SPI data input(output)
	CLUOUT0	CLU0 output
	ADC01_CH4	ADC01 channel 4
	DAC0_OUT	DAC0 out put
	DAC1_OUT	DAC1 out put
	FLT	IO filter
	EXTI0	External GPIO interrupt input signal 0
	WAKE0	External wake-up signal 0
	PU	Built-in 12kΩ Pull-up resistor which could be turn-off by software
3	P0_2	P0.2
	CLUOUT1	CLU1 output
	RST_n	P0.2 is used as RSTN by default. A 10nF-100nF capacitor should be connected to the ground. It is recommended a 12k-20k pull-up resistor is placed between RSTN and AVDD on PCB. If there is an external pull-up resistor, the capacitance of RSTN should be 100nF. The built-in 12kΩ pull-up resistor could be turned-off by software.
	FLT	IO filter
	EXTI2	External GPIO interrupt input signal 2
	WAKE1	External wake-up signal 1
	PU	Built-in 12kΩ Pull-up resistor which could be turn-off by software
4	P0_6	P0.6
	HALL_IN1	Hall interface input 1
	MCPWM_CH5N	PWM channel 5 low-side
	UART1_RXD	UART1 receive(transmit)
	SCL	I2C clock
	TIM1_CH0	Timer1 channel0



	CAN_RX	CAN Receive
	CMP2_IN	Comparator2 negative input
	FLT	IO filter
	EXTI4	External GPIO interrupt input signal 4
	WAKE2	External wake-up signal 2
	PU	Built-in 12kΩ Pull-up resistor which could be turn-off by software
5	P0_7	P0.7
	HALL_IN2	Hall interface input 2
	MCPWM_BKIN1	PWM break signal 1
	UART1_TXD	UART1 transmit(receive)
	SDA	I2C data
	TIM1_CH1	Timer1 channel1
	CAN_TX	CAN Transmit
	CMP2_IP0	Comparator2 positive input0
	FLT	IO filter
	PU	Built-in 12kΩ Pull-up resistor which could be turn-off by software
6	P0_11	P0.11
	HALL_IN0	Hall interface input 0
	TIM3_CH0	Timer3 channel0
	QEP1_CH0	Encoder1 channel0
	ADC1_CH11	ADC1 channel 11
	CMP0_IP1	Comparator0 positive input1
	FLT	IO filter
	EXTI7	External GPIO interrupt input signal 7
WAKE3	External wake-up signal 3	
7	P0_14	P0.14
	CMP0_OUT	Comparator 0 output
	MCPWM_BKIN1	PWM break signal 1
	UART0_TXD	UART0 transmit(receive)
	SPI_CLK	SPI clock
	SCL	I2C clock
	TIM0_CH1	Timer0 channel1
	QEP1_Z	QEP1 encoder Z phase
	ADC_TRIGGER0	ADC0 trigger for debug
	SIF	Single line communication
	CLUOUT0	CLU0 output
	ADC0_CH10	ADC0 channel 10
	CMP0_IP4	Comparator0 positive input4
	FLT	IO filter
	EXTI8	External GPIO interrupt input signal 8
	WAKE4	External wake-up signal 4
PU	Built-in 12kΩ Pull-up resistor which could be turn-off by software	
8	P2_7	P2.7



	CLKO	Clock output for debug
	UART0_TXD	UART0 transmit(receive)
	TIM0_CH0	Timer0 channel0
	TIM3_CH1	Timer3 channel1
	QEP1_CH1	Encoder1 channel1
	ADC_TRIGGER1	ADC1 trigger for debug
	CAN_TX	CAN Transmit
	CLUOUT1	CLU1 output
	ADC0_CH11	ADC0 channel 11
	OPA <sub>x</sub> _OUT	OPA output
	LDO15	1.5V LDO output
	REF	Reference voltage output for debug
	EXTI11	External GPIO interrupt input signal 11
	WAKE6	External wake-up signal 6
	PU	Built-in 12kΩ Pull-up resistor which could be turn-off by software
9	P3_0	P3.0
	OPA1_IP	OPA1 positive input
10	P3_1	P3.1
	OPA1_IN	OPA1 negative input
11	P1_4	P1.4
	MCPWM_CH0P	PWM channel 0 high-side
	QEP0_Z	QEP0 encoder Z phase
12	P1_5	P1.5
	MCPWM_CH0N	PWM channel 0 low-side
13	P1_6	P1.6
	MCPWM_CH1P	PWM channel 1 high-side
14	P1_7	P1.7
	MCPWM_CH1N	PWM channel 1 low-side
15	P1_8	P1.8
	MCPWM_CH2P	PWM channel 2 high-side
16	P1_9	P1.9
	MCPWM_CH2N	PWM channel 2 low-side
17	AVDD	Power supply, 2.2~5.5V
18	GND	Ground
19	P2_4	P2.4
	CMP0_OUT	Comparator 0 output
	HALL_IN0	Hall interface input 0
	MCPWM_CH2P	PWM channel 2 high-side
	UART1_RXD	UART1 receive(transmit)
	SPI_CLK	SPI clock
	TIM1_CH0	Timer1 channel0
	TIM2_CH0	Timer2 channel0
	QEP0_CH0	Encoder0 channel0



	ADC_TRIGGER0	ADC0 trigger for debug
	CAN_RX	CAN Receive
	CMP1_IP1	Comparator1 positive input1
	FLT	IO filter
	EXTI14	External GPIO interrupt input signal 14
	WAKE5	External wake-up signal 5
	PU	Built-in 12kΩ Pull-up resistor which could be turn-off by software
20	P2_14	P2.14
	SWCLK	SWD Clock
	SPI_DI	SPI data input(output)
	SCL	I2C clock
	PU	Built-in 12kΩ Pull-up resistor which could be turn-off by software

3.1.7 LKS32MC077MBS8

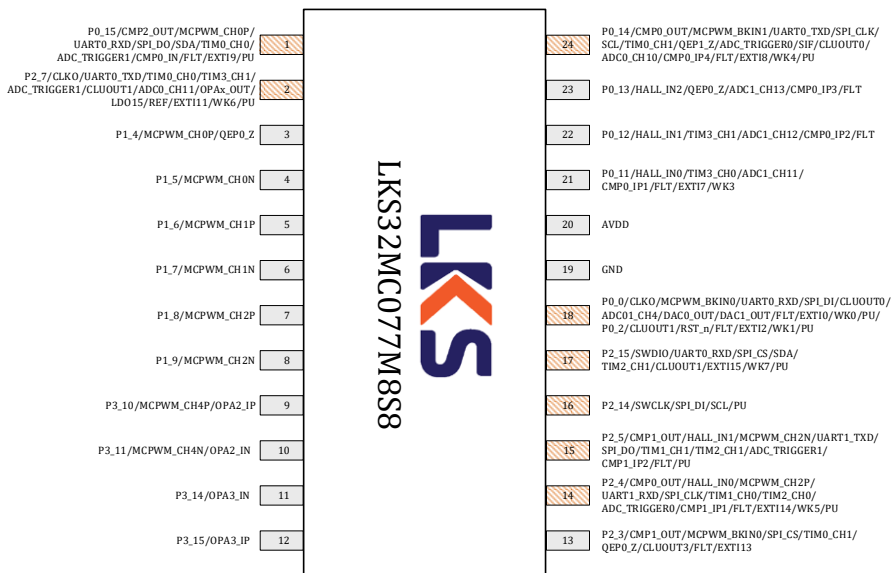

Fig.3-7 LKS32MC077MBS8 Pin Assignment

\* The red PIN pin in the figure has a built-in resistor that pulls up to AVDD: The RSTN has an internal 300 kΩ pull-up resistor and is fixed on pull-up SWDIO/SWCLK has a 12kΩ internal pull-up resistor and is fixed on pull-up. The remaining red PIN pins have built-in 12 kΩ pull-up resistors, which can be turned on and off by software control.

Table 3-7 LKS32MC077MBS8 Pin Function Description

1	P0_15	P0.15
	CMP2_OUT	Comparator 2 Output
	MCPWM_CH0P	PWM Channel 0 High Side
	UART0_RXD	Serial port 0 receive (send)

	SPI_DO	SPI Data Output (Input)
	SDA	I2C data
	TIM0_CH0	Timer0 channel 0
	ADC_TRIGGER1	ADC1 trigger signal output (for debugging)
	CMP0_IN	Comparator 0 negative input
	FLT	IO filtering
	EXTI9	External GPIO Interrupt 9
	PU	Built-in 12kΩ pull-up resistor, software switchable
2	P2_7	P2.7
	CLKO	Clock output (for debugging)
	UART0_TXD	Serial port 0 send (receive)
	TIM0_CH0	Timer0 channel 0
	TIM3_CH1	Timer3 channel 1
	ADC_TRIGGER1	ADC1 trigger signal output (for debugging)
	CLUOUT1	CLU1 output
	ADC0_CH11	ADC0 Channel 11
	OPA <sub>x</sub> _OUT	Op Amp Output
	LDO15	1.5V LDO Output
	REF	Reference Voltage
	EXTI11	External GPIO Interrupt Signal 11
	WK6	External wake-up signal 6
	PU	Built-in 12kΩ pull-up resistor, software switchable
3	P1_4	P1.4
	MCPWM_CH0P	PWM Channel 0 High Side
	QEPO_Z	QEPO Encoder Phase Z
4	P1_5	P1.5
	MCPWM_CH0N	PWM Channel 0 Low Side
5	P1_6	P1.6
	MCPWM_CH1P	PWM Channel 1 High Side
6	P1_7	P1.7
	MCPWM_CH1N	PWM Channel 1 Low Side
7	P1_8	P1.8
	MCPWM_CH2P	PWM Channel 2 High Side
8	P1_9	P1.9
	MCPWM_CH2N	PWM Channel 2 Low Side
9	P3_10	P3.10
	MCPWM_CH4P	PWM Channel 4 High Side
	OPA2_IP	Positive input of operational amplifier 2
10	P3_11	P3.11
	MCPWM_CH4N	PWM Channel 4 Low Side
	OPA2_IN	Op Amp 2 Negative Input
11	P3_14	P3.14
	OPA3_IN	Op Amp 3 Negative Input



12	P3_15	P3.15
	OPA3_IP	Positive input of operational amplifier 3
13	P2_3	P2.3
	CMP1_OUT	Comparator 1 Output
	MCPWM_BKIN0	PWM shutdown input signal 0
	SPI_CS	SPI chip select
	TIM0_CH1	Timer0 channel 1
	QEPO_Z	QEPO Encoder Phase Z
	CLUOUT3	CLU3 output
	FLT	IO filtering
EXTI13	External GPIO Interrupt Signal 13	
14	P2_4	P2.4
	CMP0_OUT	Comparator 0 Output
	HALL_IN0	HALL interface input 0
	MCPWM_CH2P	PWM Channel 2 High Side
	UART1_RXD	Serial port 1 receive (send)
	SPI_CLK	SPI clock
	TIM1_CH0	Timer1 channel 0
	TIM2_CH0	Timer2 channel 0
	ADC_TRIGGER0	ADC0 trigger signal output (for debugging)
	CMP1_IP1	Comparator 1 positive input 1
	FLT	IO filtering
	EXTI14	External GPIO Interrupt Signal 14
	WK5	External wake-up signal 5
PU	Built-in 12kΩ pull-up resistor; software switchable	
15	P2_5	P2.5
	CMP1_OUT	Comparator 1 Output
	HALL_IN1	HALL interface input 1
	MCPWM_CH2N	PWM Channel 2 Low Side
	UART1_TXD	Serial port 1 send (receive)
	SPI_DO	SPI Data Output (Input)
	TIM1_CH1	Timer1 channel 1
	TIM2_CH1	Timer2 channel 1
	ADC_TRIGGER1	ADC1 trigger signal output (for debugging)
	CMP1_IP2	Comparator 1 positive input 2
	FLT	IO filtering
PU	Built-in 12kΩ pull-up resistor; software switchable	
16	P2_14	P2.14
	SWCLK	SWD clock
	SPI_DI	SPI Data In (Out)
	SCL	I2C clock
	PU	Built-in 12kΩ pull-up resistor; software switchable
17	P2_15	P2.15



	SWDIO	SWD data
	UART0_RXD	Serial port 0 receive (send)
	SPI_CS	SPI chip select
	SDA	I2C data
	TIM2_CH1	Timer2 channel 1
	CLUOUT1	CLU1 output
	EXTI15	External GPIO Interrupt 15
	WK7	External wake-up signal 7
	PU	Built-in 12kΩ pull-up resistor; software switchable
18	P0_2	P0.2
	CLUOUT1	CLU1 output
	RST_n	Reset pin, P0.2 used as RSTN by default. It is recommended to connect a 10 nF to 100 nF capacitor to ground and place a 12 K to 20 K pull-up resistor between RSTN and AVDD. If there is an external pull-up resistor, the capacitance of RSTN should be 100 nF. P0.2 can be switched as a GPIO, which turns off the 12 kΩ pull-up resistor.
	FLT	IO filtering
	EXTI2	External GPIO Interrupt Signal 2
	WK1	External wake-up signal 1
	PU	Built-in 12kΩ pull-up resistor; software switchable
19	GND	Chip ground. It is strongly recommended that multiple ground pins be grounded uniformly on the PCB.
20	AVDD	Chip power supply, power supply range 2.5 ~ 5.5V
21	P0_11	P0.11
	HALL_IN0	HALL interface input 0
	TIM3_CH0	Timer3 channel 0
	ADC1_CH11	ADC1 Channel 11
	CMP0_IP1	Comparator 0 positive input 1
	FLT	IO filtering
	EXTI7	External GPIO Interrupt Signal 7
WK3	External wake-up signal 3	
22	P0_12	P0.12
	HALL_IN1	HALL interface input 1
	TIM3_CH1	Timer3 channel 1
	ADC1_CH12	ADC1 Channel 12
	CMP0_IP2	Comparator 0 positive input 2
	FLT	IO filtering
23	P0_13	P0.13
	HALL_IN2	HALL interface input 2
	QEPO_Z	QEPO Encoder Phase Z
	ADC1_CH13	ADC1 Channel 13
	CMP0_IP3	Comparator 0 positive input 3
	FLT	IO filtering
24	P0_14	P0.14

CMP0_OUT	Comparator 0 Output
MCPWM_BKIN1	PWM Shutdown Input Signal 1
UART0_TXD	Serial port 0 send (receive)
SPI_CLK	SPI clock
SCL	I2C clock
TIM0_CH1	Timer0 channel 1
QEP1_Z	Phase Z of QEP1 encoder
ADC_TRIGGER0	ADC0 trigger signal output (for debugging)
SIF	Single line communication
CLUOUT0	CLU0 output
ADC0_CH10	ADC0 Channel 10
CMP0_IP4	Comparator 0 positive input 4
FLT	IO filtering
EXTI8	External GPIO Interrupt Signal 8
WK4	External wake-up signal 4
PU	Built-in 12kΩ pull-up resistor, software switchable

### 3.2 Description of Pin Multiplex Function

Table 3-8 LKS32MC07X Pin Function Selection

Port	AF1	AF2	AF3	AF4	AF5	AF6	AF7	AF8	AF9	AF10	AF11	AF12	AF0
P0.0	CLKO		MCPWM_BKIN0	UART0_RXD	SPI_DI							CLUOUT0	ADC01_CH4/ DAC0_OUT/ DAC1_OUT
P0.1													ADC01_CH6
P0.2												CLUOUT1	
P0.3			MCPWM_CH4P			SCL		TIM2_CH0					ADC01_CH7
P0.4			MCPWM_CH4N			SDA		TIM2_CH1					ADC01_CH8
P0.5		HALL_IN0	MCPWM_CH5P					QEPO_Z					ADC01_CH9
P0.6		HALL_IN1	MCPWM_CH5N	UART1_RXD		SCL	TIM1_CH0			CAN_RX			CMP2_IN
P0.7		HALL_IN2	MCPWM_BKIN1	UART1_TXD		SDA	TIM1_CH1			CAN_TX			CMP2_IP0
P0.8													
P0.9						SCL		TIM2_CH0					
P0.10						SDA		TIM2_CH1					
P0.11		HALL_IN0						TIM3_CH0					ADC1_CH11/ CMP0_IP1
P0.12		HALL_IN1						TIM3_CH1		CAN_RX			ADC1_CH12/ CMP0_IP2
P0.13		HALL_IN2						QEPO_Z		CAN_TX			ADC1_CH13/ CMP0_IP3
P0.14	CMP0_OUT		MCPWM_BKIN1	UART0_TXD	SPI_CLK	SCL	TIM0_CH1	QEP1_Z	ADC_TRIGGER0		SIF	CLUOUT0	ADC0_CH10/ CMP0_IP4
P0.15	CMP2_OUT		MCPWM_CH0P	UART0_RXD	SPI_DO	SDA	TIM0_CH0		ADC_TRIGGER1				CMP0_IN



Table 3-9 LKS32MC07X Pin Function Selection (continued)

Port	AF1	AF2	AF3	AF4	AF5	AF6	AF7	AF8	AF9	AF10	AF11	AF12	AF0
P1.0			MCPWM_CH0N	UART0_TXD	SPI_DI		TIM0_BKIN						
P1.1					SPI_CS								
P1.2								TIM3_CH0					
P1.3								TIM3_CH1					ADC01_CH5
P1.4			MCPWM_CH0P					QEPO_Z					
P1.5			MCPWM_CH0N										
P1.6			MCPWM_CH1P										
P1.7			MCPWM_CH1N										
P1.8			MCPWM_CH2P										
P1.9			MCPWM_CH2N										
P1.10			MCPWM_CH3P	UART0_RXD		SCL	TIM0_CH0		ADC_TRIGGER0				ADC0_CH13
P1.11			MCPWM_CH3N	UART0_TXD		SDA	TIM0_CH1		ADC_TRIGGER1		SIF	CLUOUT2	
P1.12													
P1.13			MCPWM_CH5P		SPI_CLK		TIM0_CH0						
P1.14			MCPWM_CH5N		SPI_DO		TIM0_CH1						
P1.15			MCPWM_CH4P		SPI_DI			TIM2_CH0					



Table 3-10 LKS32MC07X Pin Function Selection (continued)

Port	AF1	AF2	AF3	AF4	AF5	AF6	AF7	AF8	AF9	AF10	AF11	AF12	AF0
P2.0			MCPWM_CH4N		SPI_CS			TIM2_CH1					
P2.1					SPI_CLK								ADC1_CH10/ CMP1_IP0
P2.2								QEP1_Z					CMP1_IN
P2.3	CMP1_OUT		MCPWM_BKIN0		SPI_CS		TIM0_CH1	QEP0_Z				CLUOUT3	
P2.4	CMP0_OUT	HALL_IN0	MCPWM_CH2P	UART1_RXD	SPI_CLK		TIM1_CH0	TIM2_CH0	ADC_TRIGGER0	CAN_RX			CMP1_IP1
P2.5	CMP1_OUT	HALL_IN1	MCPWM_CH2N	UART1_TXD	SPI_DO		TIM1_CH1	TIM2_CH1	ADC_TRIGGER1	CAN_TX			CMP1_IP2
P2.6	CMP2_OUT	HALL_IN2	MCPWM_CH3P				TIM0_BKIN	TIM3_CH0	ADC_TRIGGER0		SIF	CLUOUT0	CMP1_IP3
P2.7	CLKO			UART0_TXD			TIM0_CH0	TIM3_CH1	ADC_TRIGGER1	CAN_TX		CLUOUT1	ADC0_CH11/ OPA <sub>x</sub> _OUT/ LDO15/REF
P2.8				UART1_RXD	SPI_DO			TIM3_CH0					OSC_IN
P2.9			MCPWM_CH5P		SPI_DI	SCL							ADC0_CH12/ CMP0_IP0
P2.10			MCPWM_CH5N		SPI_DO	SDA							
P2.11			MCPWM_CH1P					TIM2_CH0					CMP2_IP1
P2.12			MCPWM_CH1N		SPI_CS			TIM2_CH1	ADC_TRIGGER0			CLUOUT3	
P2.13			MCPWM_CH3N	UART0_TXD	SPI_DO	SCL		TIM3_CH1					
P2.14	SWCLK				SPI_DI	SCL							
P2.15	SWDIO			UART0_RXD	SPI_CS	SDA		TIM2_CH1				CLUOUT1	



Table 3-11 LKS32MC07X Pin Function Selection (continued)

Port	AF1	AF2	AF3	AF4	AF5	AF6	AF7	AF8	AF9	AF10	AF11	AF12	AF0
P3.0													OPA1_IP
P3.1													OPA1_IN
P3.2			MCPWM_CH3P									CLUOUT2	
P3.3													
P3.4			MCPWM_CH3N										
P3.5													OPA0_IP
P3.6													
P3.7													OPA0_IN
P3.8													
P3.9				UART1_TXD				TIM3_CH1					OSC_OUT
P3.10			MCPWM_CH4P										OPA2_IP
P3.11			MCPWM_CH4N										OPA2_IN
P3.12													
P3.13													
P3.14													OPA3_IN
P3.15													OPA3_IP



## 4 Package size

### 4.1 LKS32MC070RBT8

LQFP64 Profile Quad Flat Package:

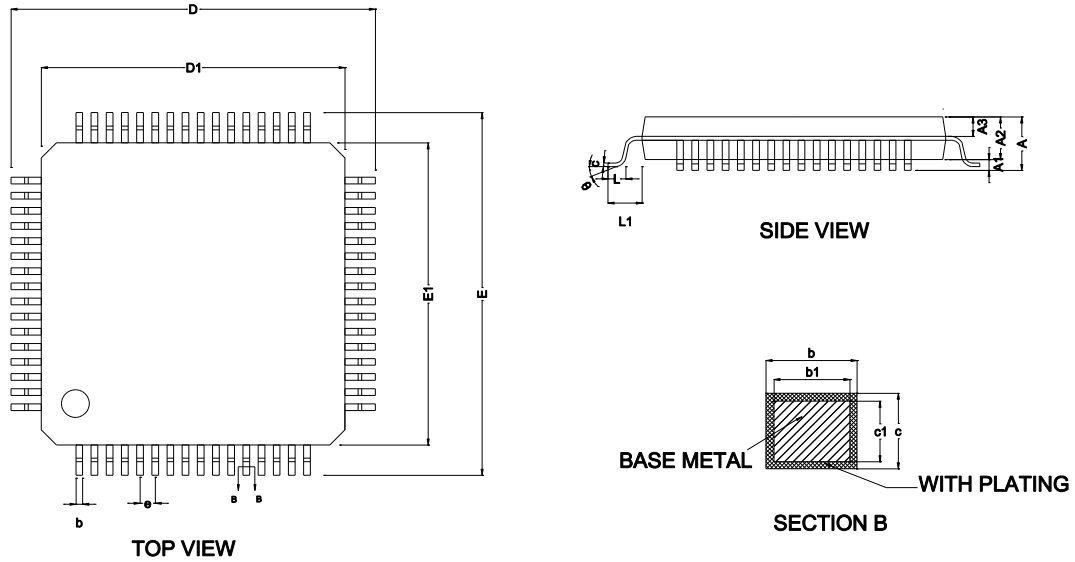

Fig.4-1 LKS32MC070RBT8 Package Diagram

Table 4-1 LKS32MC070RBT8 Package Size

SYMBOL	MILLIMETER		
	MIN	NOM	MAX
A	-	-	1.60
A1	0.05	-	0.15
A2	1.35	1.40	1.45
A3	0.59	0.64	0.69
b	0.18	-	0.26
b1	0.17	0.20	0.23
c	0.13	-	0.17
c1	0.12	0.13	0.14
D	11.80	12.00	12.20
D1	9.90	10.00	10.10
E	11.80	12.00	12.20
E1	9.90	10.00	10.10
e	0.50BSC		
L	0.45	-	0.75
L1	1.00REF		
θ	0	-	7°

### 4.2 LKS32MC071CBT8/LKS32MC071C8T8

TQFP48 Profile Quad Flat Package:

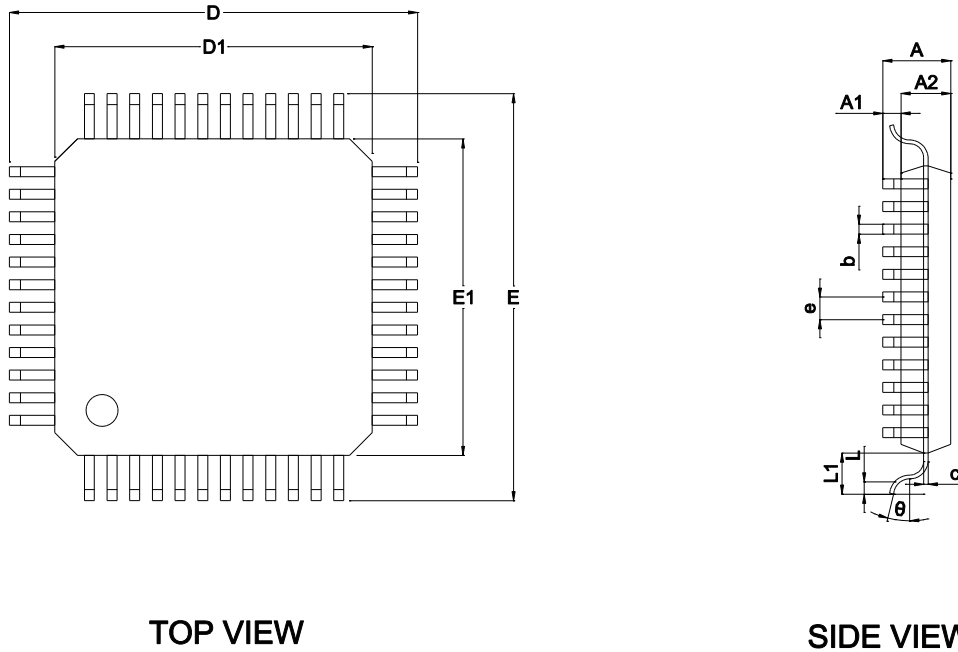
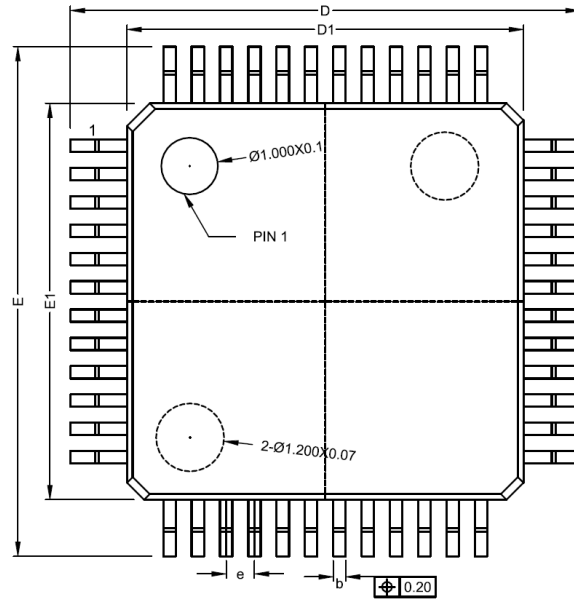

Fig.4-2 LKS32MC071CBT8/LKS32MC071C8T8 Package Diagram(TQFP48)

Table 4-2 LKS32MC071CBT8/LKS32MC071C8T8 Package Size(TQFP48)

SYMBOL	MILLIMETER		
	MIN	NOM	MAX
A	-	-	1.20
A1	0.05	-	0.15
A2	0.95	1.00	1.05
b	0.18	0.22	0.26
c	0.13	-	0.17
D	8.80	9.00	9.20
D1	6.90	7.00	7.10
E	8.80	9.00	9.20
E1	6.90	7.00	7.10
e	-	0.50	-
$\theta$	0°	3.5°	7°
L	0.45	0.60	0.75
L1	-	1.00	-



**TOP VIEW**

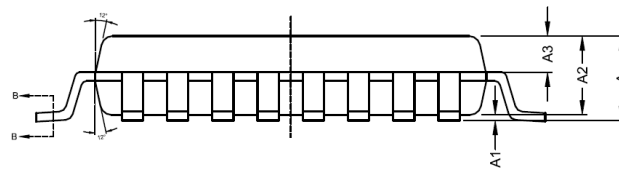

**SIDE VIEW**



图 4-3 LKS32MC071CBT8/LKS32MC071C8T8 Package Diagram(LQFP48)

表 4-3 LKS32MC071CBT8/LKS32MC071C8T8 Package Size(LQFP48)

SYMBOL	MILLIMETER		
	MIN	NOM	MAX
A	-	-	1.60
A1	0.05	0.10	0.15
A2	1.35	1.40	1.45

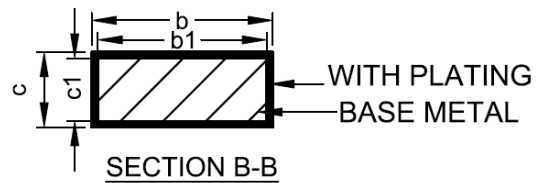
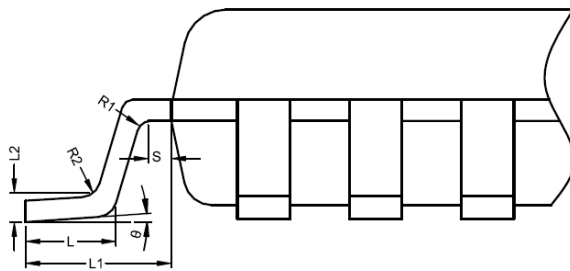

A3	0.59	0.64	0.69
b	0.18	-	0.26
b1	0.17	0.20	0.23
c	0.13	-	0.18
c1	0.12	0.13	0.14
D	8.80	9.00	9.20
D1	6.90	7.00	7.10
E	8.80	9.00	9.20
E1	6.90	7.00	7.10
e	0.50BSC		
L	0.45	-	0.75
L1	1.00REF		
L2	0.25BSC		
R1	0.08	-	-
R2	0.08	-	0.20
S	0.20	-	-
$\theta$	0°	3.5°	7°

### 4.3 LKS32MC072KBQ8

QFN5\*5 32L-0.75 Profile Quad Flat Package:

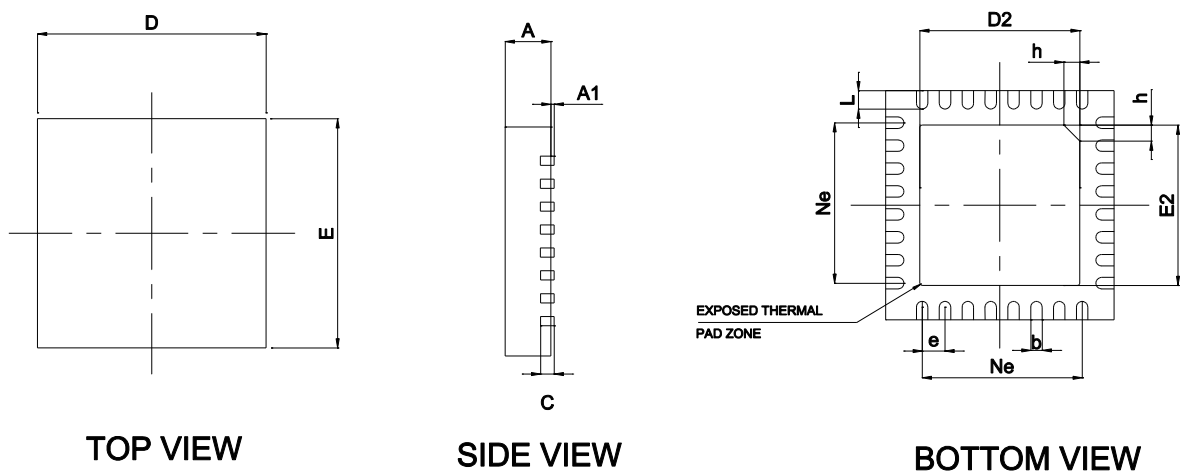

Fig.4-3 LKS32MC072KBQ8 Package Diagram

Table 4-3 LKS32MC072KBQ8 Package Size



SYMBOL	MILLIMETER		
	MIN	NOM	MAX
A	0.70	0.75	0.80
A1	-	0.02	0.05
b	0.18	0.25	0.30
c	0.18	0.20	0.24
D	4.90	5.00	5.10
D2	3.40	3.50	3.60
e	0.50BSC		
Ne	3.50BSC		
E	4.90	5.00	5.10
E2	3.40	3.50	3.60
L	0.35	0.40	0.45
h	0.30	0.35	0.40

### 4.4 LKS32MC072KBT8

LQFP32 Profile Quad Flat Package:

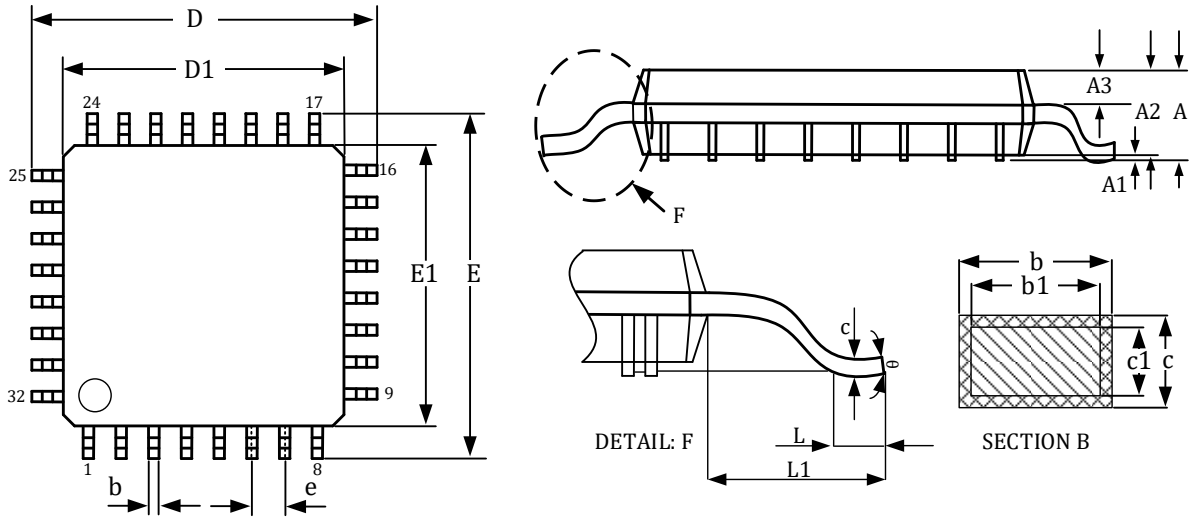

Fig.4-4 LKS32MC072KBT8 Package Diagram

Table 4-4 LKS32MC072KBT Package Size

SYMBOL	MILLIMETER		
	MIN	NOM	MAX
A	-	-	1.70
A1	0.05	0.1	0.2
A2	1.35	1.40	1.45
A3	0.59	0.64	0.69
b	0.32	0.37	0.42
b1	-	0.35	-
c	0.09	0.145	0.20
c1	-	0.125	-
D	8.80	9.00	9.20
D1	6.90	7.00	7.10
E	8.80	9.00	9.20
E1	6.90	7.00	7.10
e	0.80BSC		
L	0.30	0.50	0.70
L1	1.00REF		
θ	0	-	8°

### 4.5 LKS32MC073HBQ8

QFN3\*3 20L-0.75 Profile Quad Flat Package:

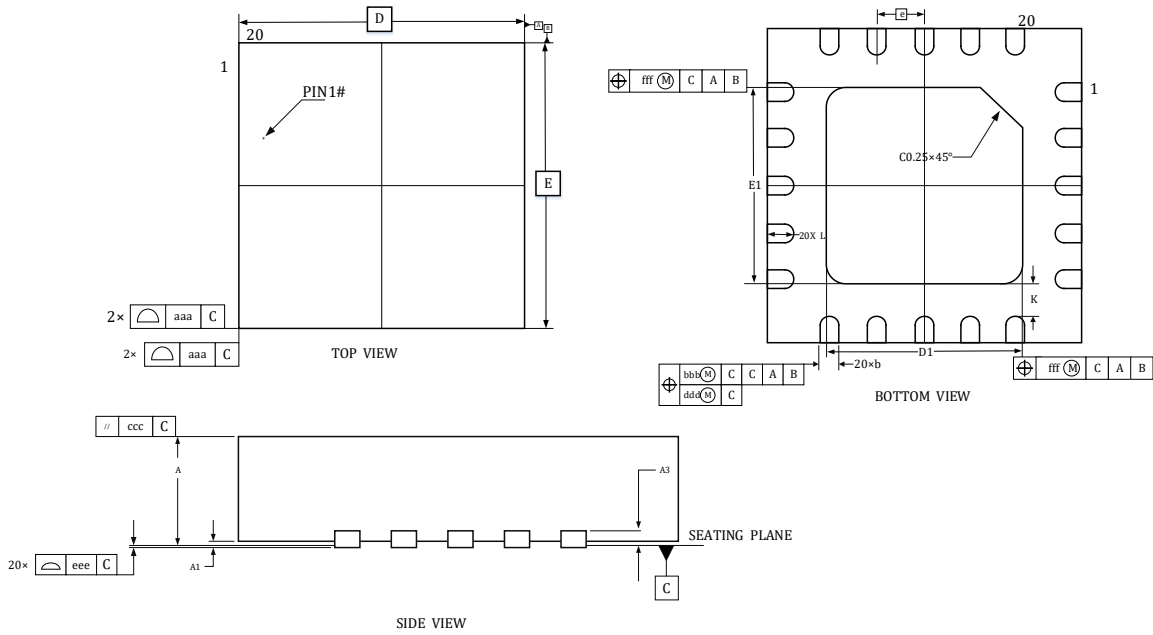

Fig.4-5 LKS32MC073HBQ8 Package Diagram

Table 4-5 LKS32MC073HBQ8 Package Size

SYMBOL	MIN.	NOM.	MAX.
A	0.50	0.55	0.60
A1	0	0.02	0.05
A3	-	0.152 REF	-
b	0.15	0.20	0.25
D	3.00BSC		
E	3.00BSC		
D1	1.60	1.70	1.80
E1	1.60	1.70	1.80
e	0.40BSC		
L	0.25	0.30	0.35
K	0.20	-	-
aaa	0.10		
bbb	0.07		
ccc	0.10		
ddd	0.05		
eee	0.08		
fff	0.10		

### 4.6 LKS32MC077MBS8

SSOP24L Profile Quad Flat Package:

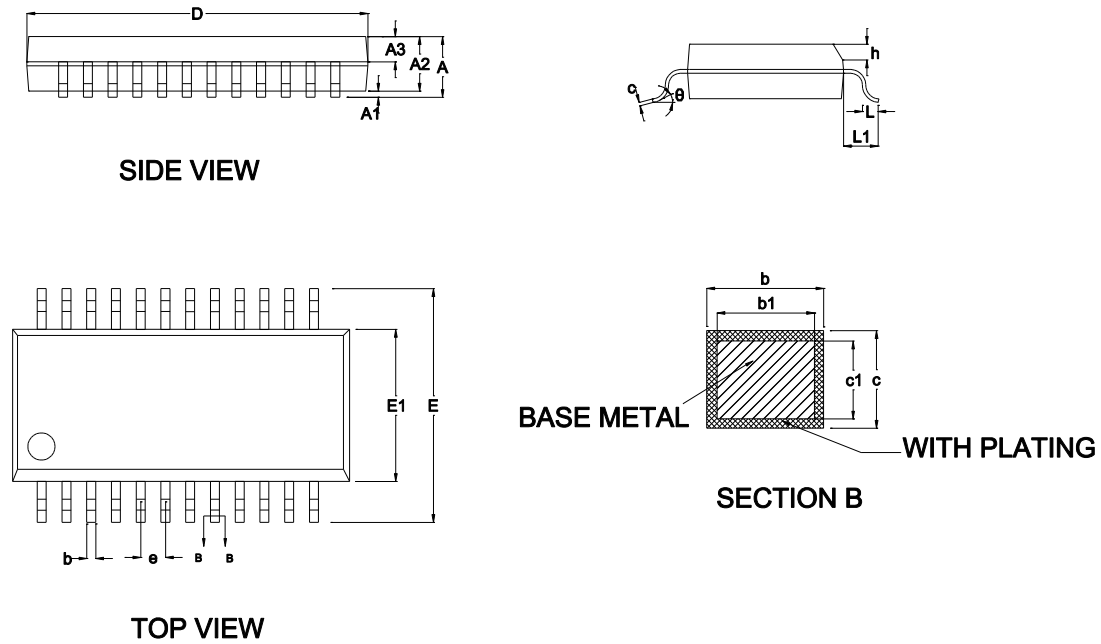

Fig.4-6 LKS32MC077MBS8 Package Diagram

Table 4-6 LKS32MC077MBS8 Package Size

SYMBOL	MILLIMETER		
	MIN	NOM	MAX
A	-	-	1.75
A1	0.10	0.15	0.25
A2	1.30	1.40	1.50
A3	0.60	0.65	0.70
b	0.23	-	0.31
b1	0.22	0.25	0.28
c	0.20	-	0.24
c1	0.19	0.20	0.21
D	8.55	8.65	8.75
E	5.80	6.00	6.20
E1	3.80	3.90	4.00
e	0.635BSC		
h	0.30	-	0.50
L	0.50	-	0.80
L1	1.05REF		
θ	0	-	8°

\*Support IEC/UL60730 functional security certification

## 5 Electrical performance parameters

Table 5-1 LKS32MC07x electrical absolute characteristics

Parameter	Min.	Max.	Unit	Explain
MCU Power Supply Voltage (AVDD)	-0.3	+6.0	V	
Gate Driver Power Supply Voltage (VCC)	-0.3	+25.0	V	LKS07x with 6N driver
	-0.3	+40.0	V	LKS07x with 3P3N driver
Supply Voltage (VCCLDO)	-0.3	+25.0	V	Pin for LDO supply in 074do
Operating temperature	-40	+105	°C	
Storage temperature	-40	+150	°C	
Junction temperature	-	125	°C	
Pin temperature (soldering for 10 seconds)	-	260	°C	

Table 5-2 LKS32MC07x Recommended working condition parameters

Parameter	Mini.	Typ.	Max.	Unit	Explain
MCU Power Supply Voltage (AVDD)	2.5	5	5.5	V	
Analog Power Supply Voltage (AVDD <sub>A</sub> )	2.8	5	5.5	V	REF2VDD = 0, ADC selects 2.4 V internal reference
	2.4	5	5.5	V	REF2VDD = 1, ADC selects AVDD as reference

Table 5-3 LKS32MC07x ESD Parameters

Item	Minimal	Max	Unit
ESD Test (HBM)	-6000	6000	V

According to "MIL-STD-883J Method 3015.9", under the environment of 25°C and 55% relative humidity, electrostatic discharge is applied to all IO pins of the tested chip for 3 times, with an interval of 1s each time. The test results show that the anti-static discharge level of the chip reaches Class 3A  $\geq 4000V$ ,  $< 8000V$ .

Table 5-4 LKS32MC07x Latch-up parameters

Item	Minimal	Max	Unit
Latch-up current (85 °C)	-200	200	mA

According to "JEDEC STANDARD NO.78E NOVEMBER 2016", an overvoltage of 8 V is applied to all power supply IOs, and a current of 200 ma is injected on each signal IO. The test results show that the anti-latch-up level of the chip is 200 mA.

Table 5-5 LKS32MC07x IO absolute characteristics

Parameter	Description	Min.	Max.	Unit
V <sub>IN</sub>	GPIO Signal Input Voltage Range	-0.3	6.0	V
I <sub>INJ_PAD</sub>	Maximum Injection Current of A Single GPIO	-11.2	11.2	mA
I <sub>INJ_SUM</sub>	Maximum Injection Current of All GPIOs	-50	50	mA

Table 5-6 LKS32MC07x IO DC Parameters

Parameter	Description	AVDD	Conditions	Min.	Max.	Unit
V <sub>IH</sub>	High input level of digital IO	5V	-	3.06		V
		3.3V		2.07		
V <sub>IL</sub>	Low input level of digital IO	5V	-		0.3*AVDD	V
		3.3V			0.8	
V <sub>HYS</sub>	Schmidt hysteresis range	5V	-	0.1*AVDD		V
		3.3V				
I <sub>IH</sub>	Digital IO current consumption when input is high	5V	-		1	uA
		3.3V				
I <sub>IL</sub>	Digital IO current consumption when input is low	5V	-	-1		uA
		3.3V				
V <sub>OH</sub>	High output level of digital IO		Current = 11.2mA	AVDD-0.8		V
V <sub>OL</sub>	Low output level of digital IO		Current = 11.2mA		0.5	V
R <sub>pup</sub>	Pull-up resistor*			11	13	kΩ
R <sub>io-ana</sub>	Connection resistance between IO and internal analog circuit			100	200	Ω
C <sub>IN</sub>	Digital IO Input-capacitance	5V	-		10	pF
		3.3V				

Table 5-7 LKS32MC07x Module Current/IDD

模块	Min	Typ	Max	单位
Comparator x1		0.005		mA
OPA x1		0.450		mA
ADC		3.710		mA
DAC		0.710		mA
Temp Sensor		0.150		mA
Band-Gap		0.154		mA
4MHz RC Clock		0.105		mA
PLL		0.080		mA
CPU+flash+SRAM (96MHz)		8.667		mA
CPU+flash+SRAM (12MHz)		1.600		mA
CRC		0.070		mA
DSP		3.421		mA
UART		0.107		mA
DMA		1.340		mA
MCPWM		0.053		mA



TIMER		0.269		mA
SPI		0.500		mA
IIC		0.500		mA
CAN		2.200		mA
Sleep Mode	9	12	20	uA

Unless otherwise noted, the above tests are conducted under the condition of 25 ° 5V power supply at room temperature and 96MHz clock. Due to the device model deviation in the manufacturing process, the current consumption of different chips will be different.

## 6 Analog Characteristics

Table 6-1 LKS32MC07x analog characteristics

Parameter	Min.	Typ.	Max.	Unit	Explain
<b>MCU</b>					
Power Supply Voltage	2.5	5	5.5	V	
<b>Analog-to-digital converter (ADC)</b>					
Power Supply	3.3	5	5.5	V	ADC use 2.4V internal reference
	2.8	5	5.5	V	ADC use 1.2V internal reference
Sampling rate		3		MHz	fadc/16
Differential Input Signal Range	-5.0 +0.144		+5.0 -0.144	V	When ADCx_GAIN = 1; REF=2.4V
	-3.6 +0.072		+3.6 -0.072	V	When ADCx_GAIN = 0; REF=2.4V
Single-ended Input Signal Range	-0.3		AVDD +0.3	V	Limited by the input voltage of the IO port
<p>The differential signal is usually the signal output from the OPA inside the chip to the ADC; Single-ended signals are typically sampled externally via an IO input: The ADC should measure the signal amplitude no more than <math>\pm 98\%</math> of the full scale, regardless of the internal/external reference used. In particular, when using an external reference, it is recommended that the sampling conductor not exceed 90% of the scale.</p>					
DC offset		5	10	mV	Correctable
Effective number of bits (ENOB)	10.5	11		bit	
INL		2	3	LSB	
DNL		1	2	LSB	
SNR	63	66		dB	
Input Resistance	500k			Ohm	
Input Capacitance		10		pF	
<b>Reference Voltage (REF)</b>					
Power Supply	2.2	5	5.5	V	
Output Deviation	-9		9	mV	
Rejection Ratio of Power Sup-		70		dB	

Parameter	Min.	Typ.	Max.	Unit	Explain	
<b>MCU</b>						
Power Supply Voltage	2.5	5	5.5	V		
Temperature Coefficient		20		ppm/°C		
Output Voltage		1.2		V		
<b>Digital-to-Analog Converter (DAC)</b>						
Power Supply	2.2	5	5.5	V		
Load Resistance	5k			Ohm	Output BUFFER is on	
Load capacitance			50p	F		
Output voltage range	0.05		AVDD-0.1	V		
Conversion speed			1M	Hz		
DNL		1	2	LSB		
INL		2	4	LSB		
OFFSET		5	10	mV		
SNR	57	60	66	dB		
<b>Operational Amplifier (OPA)</b>						
Power Supply	2.8	5	5.5	V		
Bandwidth		10	20	MHz		
Load Resistance	20k			Ohm		
Load Capacitance			5p	F		
Input Common Mode Voltage Range (VICM)	0		AVDD	V		
Output Signal Range	0		2Vcm	V	Under minimum load resistance	
Common Mode Voltage (Vcm)	1.45	1.8	2.2	V	32 times	Measurement condition: normal temperature. Operational amplifier swing=2 × min(AVDD-Vcm, Vcm). It is recommended that the application using OPA single output should be powered on to measure Vcm and make software subtraction correction.
	1.5	1.8	2.2	V	16 times	
	1.55	1.8	2.2	V	8 times	
	1.6	1.8	2.2	V	4 times	



Parameter	Min.	Typ.	Max.	Unit	Explain
<b>MCU</b>					
Power Supply Voltage	2.5	5	5.5	V	
					For more analysis, please refer to the official website application note "ANN009 - Differences between Operational Amplifier Differential and Single Operating Mode".
OFFSET		10	15.0	mV	32 times
		10	16.5	mV	16 times
		10	18.5	mV	8 times
		10	20.5	mV	4 times
This OFFSET is the equivalent differential input deviation obtained when the OPA differential input is short-circuited and OPA OUT is measured from 0 level. The output deviation of OPA is OPA magnification x OFFSET. The Flash NVR area records the OPA offset for factory tests.					
Common Mode Rejection Ratio (CMRR)		80		dB	
Power Supply Rejection Ratio (PSRR)		80		dB	
Load Current			500	uA	
Slew Rate		5		V/us	
Phase Margin (PM)		60		Degree	
<b>Comparator (CMP)</b>					
Power Supply	2.2	5	5.5	V	
Input Signal Range	0		AVDD	V	
OFFSET	-36	-10	12	mV	0 mV hysteresis, CMP output transitions from low to high
	-36	-10	12	mV	0 mV hysteresis, CMP output transitions from high to low
	-14.5	-10	33.5	mV	20 mV hysteresis, CMP output transitions from low to high
	-14.5	11.5	33.5	mV	20 mV hysteresis, CMP output transitions from high to low
Delay		50		nS	Default power consumption
		200		nS	Low power consumption
Hysteresis		20		mV	HYS='0'
		0		mV	HYS='1'



**Analog register table description:**

The names of the analog registers are SYS\_AFE\_REG0 to SYS\_AFE\_REG6, corresponding to addresses 0x4000\_0010 to 0x4000\_0028. Address 0x4000\_001C to 0x4000\_0028 are the calibration registers of each analog module. These registers will fill their respective calibration values into the Flash info area before leaving the factory, and will be automatically loaded to the SYS\_AFE\_REG3 to SYS\_AFE\_REG6 after power-on. In general, the user should not configure or change these values. If fine-tuning is required, please read the original settings first, and then adjust based on those values.

Addresses space of 0x4000\_0000 to 0x4000\_0018 are registers open to users. The blank registers must be configured to 0 (these registers will be reset to 0 after power on). Other registers could be configured in situations.



## 7 Power management system

The power management system is composed of LDO15 module, power detection module (PVD), power-on/power-off reset module (POR).

AVDD is powered by a 2.5V ~ 5.5V supply, and all internal digital circuits and PLL modules are powered by an internal LDO15.

The LDO15 is automatically turned on after power-on. No software configuration is necessary. And the LDO15 output voltage can be adjusted by software.

The output voltage of LDO15 can be adjusted by setting register LDO15TRIM<2:0>. The corresponding value of the register can be seen in the analog register table. LDO15 has been calibrated before it leaves the factory. Generally, users do not need to configure these registers again. If fine-tuning of the LDO output voltage is required, please read the original configuration value first, and then calculate the new settings accordingly.

The POR module monitors the voltage of the LDO15. When the voltage of the LDO15 is lower than 1.26V, for example, at the beginning of power-on or at the time of power-off, it will provide a reset signal for the digital circuit to avoid any abnormal operation.

The PVD module monitors the 5V input power. If it is below a certain threshold, it will remind the MCU by sending an alarm (interrupt) signal. The interrupt reminder threshold can be set to different voltages through the PVDSEL<1:0> registers. The PVD module can be turned off by setting PD\_PDT = '1'. For the corresponding value of specific register, please refer to the analog register table.

## 8 Clock system

The clock system consists of a 32KHz RC oscillator, a 8MHz RC oscillator, an external 8MHz crystal oscillator, and a PLL.

The 32K RC clock is used in the MCU system as a slow clock for modules such as reset/wakeup source filters or used in the low power mode; The 8MHz RC clock can be used as the main clock of the MCU, and can provide a reference clock to PLL. PLL clock is up to 96MHz; The external 8MHz crystal oscillator is used as a backup clock.

Both 32k and 8M RC clocks will be through factory calibration. In the range of -40 ~ 105 °C, the accuracy of the 32K RC clock is  $\pm 50\%$ , and the accuracy of the 8M RC clock is  $\pm 1\%$ .

The frequency of the 32K RC clock can be set by the register RCLTRIM<3:0>, and the frequency of the 8M RC clock can be set by the register RCHTRIM <5:0>. For the corresponding value of specific register, please refer to the analog register table.

The chip has been calibrated before it leaves the factory. Generally, users do not need to configure these registers again. If fine-tuning of the frequency is required, please read the original configuration value first, and then calculate the new settings accordingly.

The 8M RC clock is turned on by setting RCHPD = '0' (ON by default, turn off when set to "1'). The RC clock needs a reference voltage and current provided by the Bandgap voltage reference module; thus, do remember to turn on the BGP module before turning on the RC clock. When the chip is powered on, the 8M RC clock and BGP module are both turned on automatically. The 32K RC clock is always on and cannot be turned off.

The PLL multiplies the 8M RC clock to provide a higher frequency clock for modules like MCU and ADC. The highest frequency of MCU and PWM module is 96MHz, and the typical working frequency of ADC module is 48MHz. It can be set to different frequency by the register ADCLKSEL <1:0>.

PLL is turned on by setting PLLPDN = '1' (OFF by default, turn on when set to '1'). Before turning on the PLL module, the BGP (Bandgap) module should be turned on first. After the PLL is turned on, it needs a settling time of 6 $\mu$ s to achieve a stable frequency output. When the chip is powered on, the RCH clock and BGP module are both turned on. PLL is OFF by default and could be enabled by software.

The crystal oscillator circuit has a built-in amplifier and an oscillator capacitor. Connect a crystal between IO OSC\_IN/OSC\_OUT and set XTALPDN = '1' to start the oscillation.

## 9 Voltage Reference

Reference voltage and current are provided for ADC, DAC, RC clock, PLL, temperature sensor, operational amplifier, comparator and FLASH. Before using any of the above modules, the BGP voltage reference should be turned on first.

When the chip is powered on, the BGP module is turned on automatically. The voltage reference is turned on by setting BGPPD = '0'. From OFF to ON, BGP needs about 6 $\mu$ s to stabilize. BGP output voltage is about 1.2V, and accuracy is  $\pm 0.8\%$ .



## 10 ADC module

The chip integrated a synchronous double-sampling SAR ADC which is shut down by default when the chip is powered up. Before turning on ADC, the BGP module, 8M RC clock and PLL should be turned on first. In the default configuration, ADC clock is 48MHz, which corresponds to a conversion rate of 3Msps.

The synchronous double sampling circuit can sample the two input analog signals at the same time. After the sampling is completed, the ADC converts the two signals one by one and writes them into the corresponding data registers.

ADC takes 16 ADC clock cycles to complete one conversion, of which 13 are conversion cycles and 3 are sampling cycles. I.E.  $f_{conv}=f_{adc}/16$ . When the ADC clock is set to 48MHz, the conversion rate is 3Msps.

When the ADC is working at a lower frequency, the power consumption can be reduced by setting register CURRIT<1:0>.

ADC could work in different modes: One-time single channel trigger mode, continuous single channel sampling mode, One-time 1 to 20 channels scanning mode, continuous 1 to 20 channels scanning mode. It has a set of 20 independent registers for each analog channel.

The ADC trigger can be MCPWM/Timer trigger signals T0, T1, T2 and T3 happened for the preset number of times, or software trigger event.

ADC\_DC stores the DC offset of ADC. Usually, in the calibration phase, the ADC DC offset value is obtained by measuring the AVSS (internal ground) of Channel 15 (counting from 0) and stored in flash. In the system loading phase, the DC offset is written into the ADC\_DC register by software.

The ADC has two ranges set by the ADC\_X\_GAIN (X = 0, 1): 3.6 V and 7.2 V. At the 7.2 V range, this corresponds to a maximum input signal amplitude of  $\pm 5$  V because the chip is powered at 5 V. At the 3.6 V range, this corresponds to a maximum input signal amplitude of  $\pm 3.6$  V. When measuring the output signal of an op amp, select the specific ADC gain based on the maximum signal that the op amp can output.



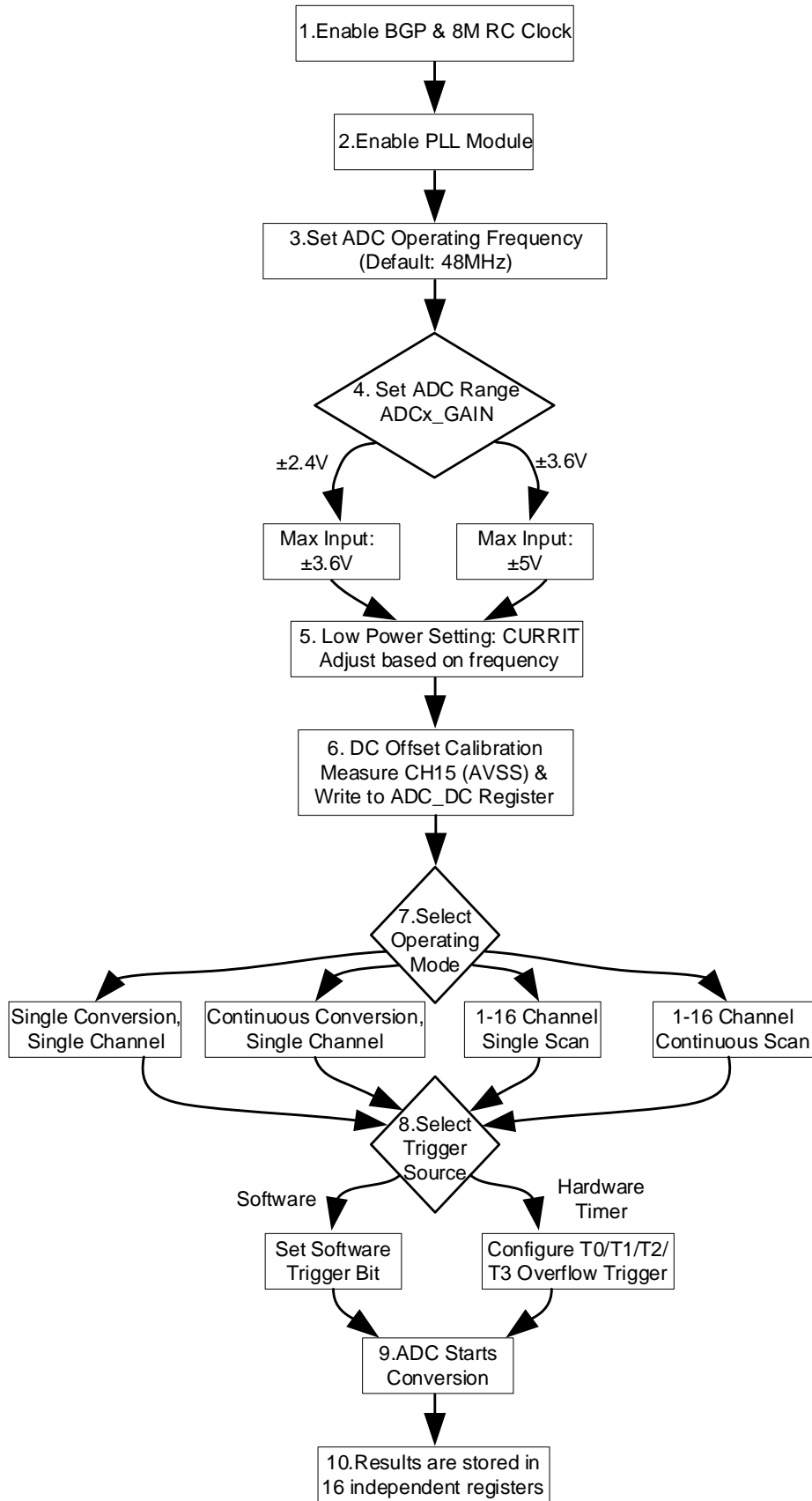

Figure 10-1ADC Configuration Flowchart



# 11 SPI module



图 11-1 SPI Slave Mode Timing Diagram



图 11-2 SPI Slave Mode Timing Diagram with CHPA=0



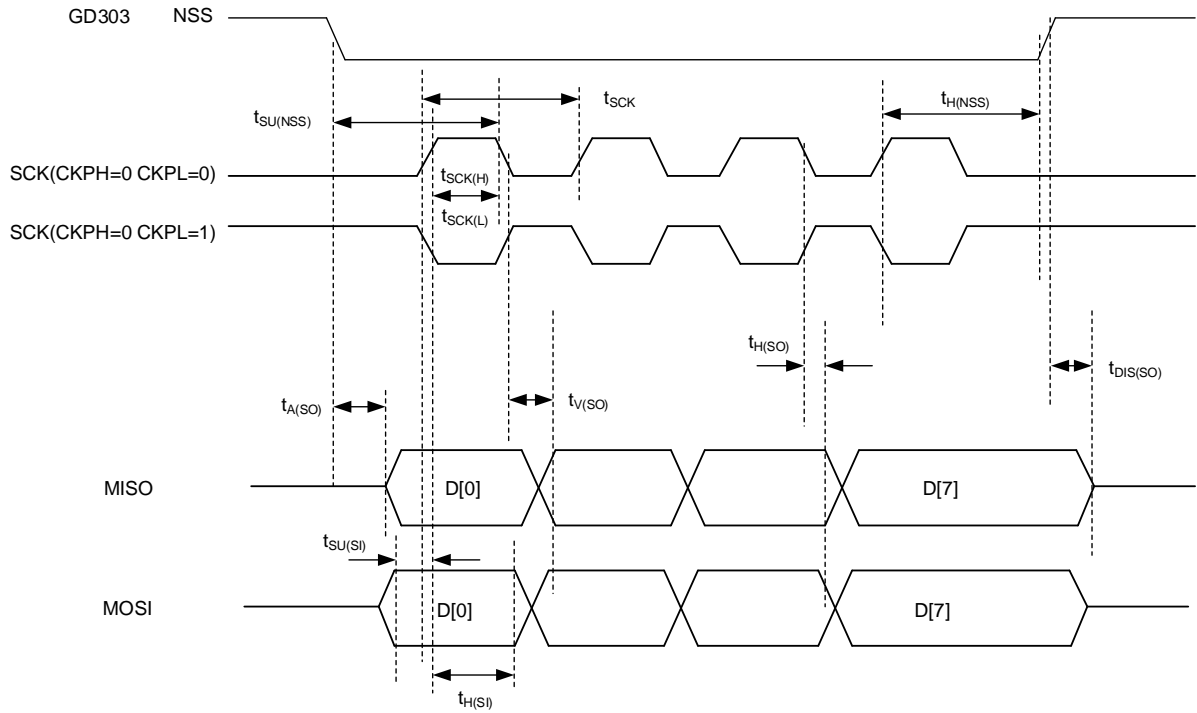

图 11-3 SPI Master Mode Timing Diagram

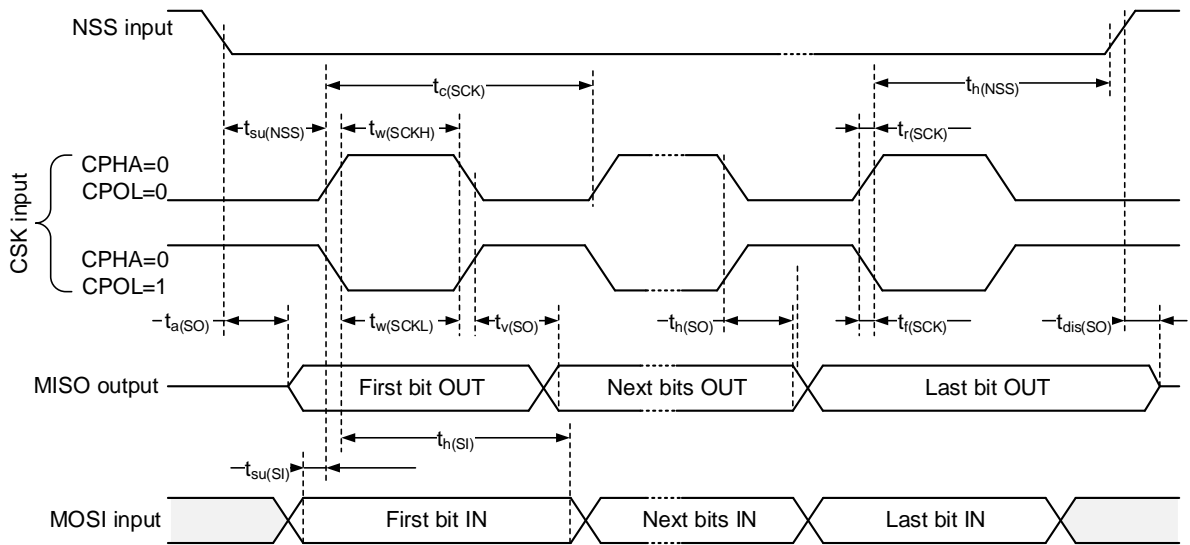
Table 11-1 SPI Timing Parameters Table

SPI mode, polarity 0, phase 0, rising edge sampling, falling edge output

Parameter	Min.	Typical	Max.	Unit	Description
$f_{SCK}$	—	—	12	MHz	Theoretical value, with a 1% margin of error in actual measurements. The maximum allowable baud rate is 12 MHz.
$t_{SCK(H)}$	41.25	41.67	42.09	nS	Half SCK cycle
$t_{SCK(L)}$	41.25	41.67	42.09	nS	Half SCK cycle
<b>SPI master mode</b>					
$t_{V(MO)}$	—	9.9	10	nS	CLK falling edge to MOSI new data start validity
$t_{H(MO)}$	2	—	—	nS	CLK falling edge to MOSI old data start transition
$t_{SU(MI)}$	-25	—	—	nS	MISO to CLK rising edge setup time requirement
$t_{H(MI)}$	40	—	—	nS	MISO to CLK rising edge hold time requirement
<b>SPI slave mode</b>					
$t_{SU(NSS)}$	20	—	—	nS	The chip select signal is pulled low at the <b>first rising edge</b> of CLK.
$t_{H(NSS)}$	-40	—	—	nS	The rising edge of the last CLK signal pulls the chip select high.
$t_{A(SO)}$	51.5	—	52.5	nS	Lower the frame selection to MISO to begin sending data.
$t_{DIS(SO)}$	47.5	—	48.5	nS	Raise the selection to MISO 0
$t_{V(SO)}$	—	38	38.4	nS	From the falling edge of CLK to the completion of new data transmission
$t_{H(SO)}$	29.2	—	—	nS	From the falling edge of CLK to the start of old data change

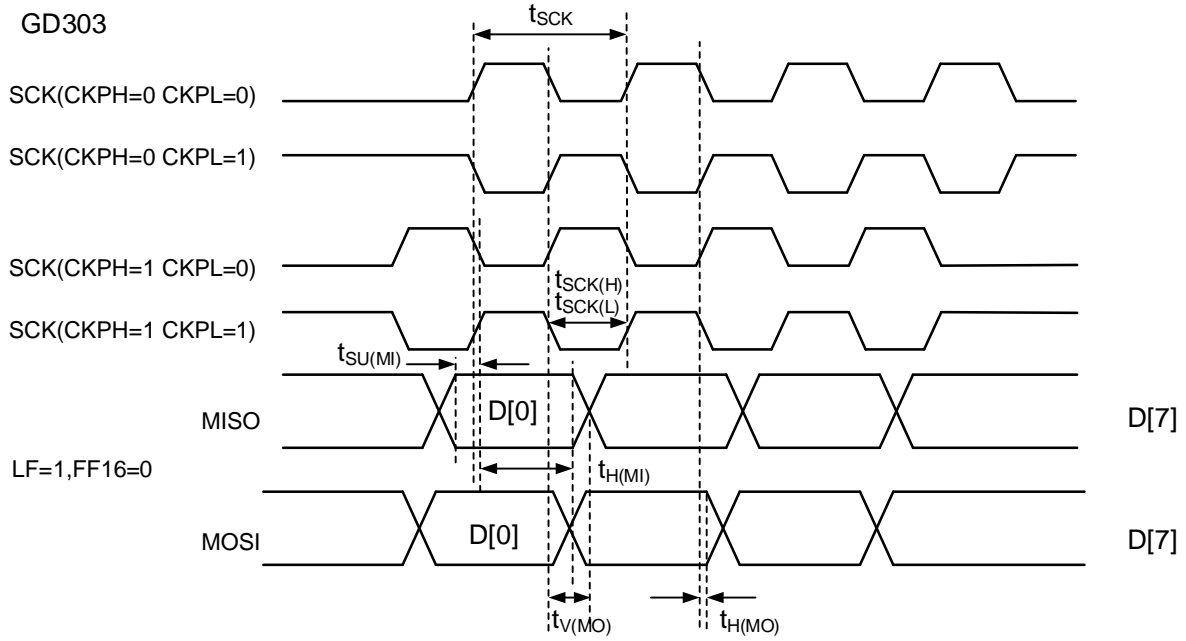

$t_{SU(S)}$	-20	—	—	nS	From MOSI signal stabilization to the rising edge of CLK
The chip operates at 3.3V and was tested at a clock frequency of 96MHz (when powered at 5V, significant ringing appears on the oscilloscope probe; probe cable length is 1m).					



## 12 Operational Amplifier

4-channel of rail-to-rail OPAs are integrated, with a built-in feedback resistor  $R2/R1$ . A resistor  $R0$  is required to be connected in series to the external pin. The resistance of feedback resistors  $R2:R1$  can be adjusted by register  $RES\_OPA0<1:0>$  to achieve different gain. For the corresponding value of specific register, please refer to the analog register table.

The close-loop gain of OPA is  $R2/(R1+R0)$ , where  $R0$  is the resistance of the external resistor.

For the application of MOS resistance direct sampling, it is recommended to connect an external resistance of  $>20k\Omega$  to reduce the current flowing into the chip pin when the MOS is turned off;

For the application of small resistance sampling, it is recommended to connect an external resistor of  $100\Omega$ .

The OPA can select one of the output signals of the 4-channels amplifiers by setting  $OPAOUT\_EN<2:0>$ , and send it to the P2.7 IO port through a buffer for measurement (see the corresponding relationship in the datasheet 'Pin Function Description" ). Because of this buffer, the OPA is able to be output to an IO while operating normally.

When the chip is powered on, the OPA module is OFF by default. It can be turned on by setting  $OPAxPDN = '1'$ , and turn on the BGP module before turning on the amplifier.

For built-in clamp diodes are integrated between the positive and negative OPA inputs, the motor phase line could be directly connected to the OPA input through a matching resistor, thereby simplifying the external circuit for MOSFET current sampling.

## 13 Comparator

Built-in 3-channel rail-to-rail comparators with programmable comparator speed, hysteresis voltage, and signal source.

The comparison delay of the comparator can be set to  $< 30\text{nS}/200\text{ nS}$  through Register `CMP _ FT`. The hysteresis voltage is set to  $20\text{ mV}/0\text{ mV}$  by the `CMP _ HYS`.

The comparator positive input signal source can be set by register `CMPx _ SELP [2:0]`; the comparator negative input signal source can be set by register `CMPx _ SELN [1:0]` ( $X = 0/1/2$  for comparators `CMP0/CMP1/CMP2`).

When the chip is powered on, the comparator module is OFF by default. The comparator is turned on by setting `CMPxPDN = '1'`, and turn on the BGP module before turning on the comparator.



## 14 Temperature sensor

The chip has a temperature sensor with an accuracy of  $\pm 2^{\circ}\text{C}$ . The temperature sensor will be calibrated in factory, and the calibration value is saved in the flash info area.

When the chip is powered on, the temperature sensor module is OFF by default. Turn on the BGP module before turning on the temperature sensor.

The temperature sensor is turned on by setting  $\text{TMPPDN} = '1'$ , and it takes about  $2\mu\text{s}$  to be stable after turning on. Thus, it should be turned on at least  $2\mu\text{s}$  ahead before the ADC measures the sensor output.



## 15 DAC module

The chip contains two 12-bit DACs, and the maximum range of the output signal can be set to 1.2 V/4.85 V using the DAC0 \_ GAIN and DAC1 \_ GAIN registers.

DAC0 can route the DAC0 output to the P0.0 pin through the configuration register DAC0OUT \_ EN = 1, and DAC1 can route the DAC1 output to the P0.0 pin through the configuration register DAC1OUT \_ EN = 1, which can drive a load resistor of > 5kΩ and a load capacitance of 50pF. Normally, DAC0 and DAC1 are not output at the same time to avoid signal contention.

The maximum output bit rate of DAC is 1MHz.

When the chip is powered on, the DAC module is OFF by default. DAC0 can be turned on by setting DAC0PDN = 1, and DAC1 can be turned on by setting DAC1PDN = 1. Before turning on the DAC module, you need to turn on the BGP module.

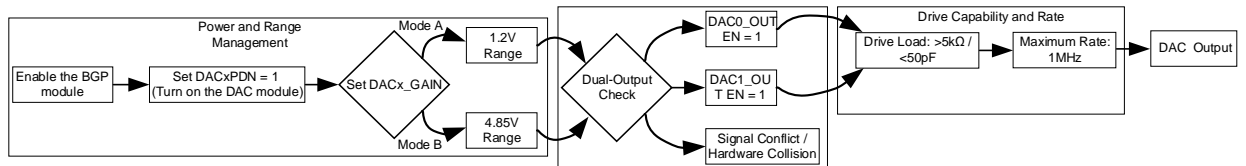

Figure 15-1 DAC Configuration Flowchart

## 16 Processor core

- 32-bit Cortex-M0 + DSP dual-core processor
- Two-wire SWD debug pin
- System frequency is up to 96MHz



## 17 Storage resources

### 17.1 Flash

- built-in flash including 64kB/128kB main area and 1.5kB NVR
- Endurance: 100,000 Cycles(min)
- Data retention: more than 100 years
- Single byte program: 7.5us(max), Sector erase: 5ms(max)
- Sector size 512bytes, supporting Sector erase/program and in-application program
- Flash data anti-theft by programming the last word of flash to any words other than 0xFFFFFFFF

### 17.2 SRAM

- built-in 12kB SRAM



## 18 MCPWM for motor drive

- MCPWM operating frequency is up to 96MHz
- It can generate 6 pairs of non-overlapping PWM signals (complementary mode) or 12 independent non-overlapping PWM signals (edge-aligned mode). The module consists of two chopper modules, with each group sharing one dead-time configuration.
- Support edge-aligned PWM
- Support software control IO mode
- Support IO polarity control
- Internal short circuit protection to avoid short circuit due to configuration error
- External short circuit protection, enabling fast shutdown by monitoring the external signals
- Internal ADC sampling interrupt
- Preload MCPWM register configuration and update simultaneously
- Programmable load time and period



## 19 Timer

- 4-channel standard timer, 2-channel 16-bit timer, 2-channel 32-bit timer.
- Support capture mode for measuring external signal/pulse width
- Support comparison mode for timed interruption of edge-aligned PWM

In particular, LKS32MC070/ LKS32MC071/ LKS32MC072/ LKS32MC077 has 2 channels to support coded signal input and support pulse instruction counting.

## 20 Hall sensor interface

- Built-in 1024 cycles filtering
- 3-channel Hall signal input
- 24-bit counter, with overflow and capture interrupt



## 21 DMA

- One DMA engine
- Supporting up to 4 channels
- Supporting byte/halfword/word transfers of different sizes
- Supporting different address increment mode
- Supporting data transfer between flash/ram/peripherals
- Supporting cycle mode



## 22 DSP

- Customized DSP instruction set for motor control algorithm, , three-stage pipeline architecture
- Operating frequency is up to 96MHz
- 32/16-bit divider, could finish one division calculation in 12 cycles (96MHz)
- 32-bit hardware SQRT, could finish one SQRT calculation in 8 cycles (96MHz)
- Q15 format Cordic trigonometric function module, could finish sin/cos/artanc calculation in 20 cycles (96MHz)
- DSP has independent program memory and data memory, DSP could execute its program independently, and can also be called by MCU to perform a certain calculation as a AHB slave like a coprocessor
- Support DSP IRQ and pause state for data exchange purpose with MCU



## 23 CRC

- Supporting polynomials of different bit widths such as 7/8/16/32
- Supporting polynomial coefficient configuration
- Supporting input and output data flipping



## 24 General Purpose Peripheral

- Two UART, full-duplex operation, support 8/9 data bit, 1/2 stop bit, odd/even/no parity mode, with 1 byte tx buffer, 1 byte rx buffer, support Multi-drop Slave/Master mode, support 300 to 115200 baud rate
- One SPI, support master-slave mode
- One IIC, support master-slave mode
- One CAN-bus
- Hardware watchdog, driven by 32kHz RC clock and which is independent of system high-speed clock, the minimum reset interval was  $4096/32\text{kHz} \approx 128\text{ms}$ , and the maximum reset interval was  $511 \times 4096/32\text{kHz} \approx 64\text{s}$ .

Please refer to Section 2 Selection table for different types of peripherals.



## 25 Special IO multiplexing

### Notes for Special IO Multiplexing of LKS07x

The SWD protocol includes two signals: SWCLK and SWDIO. SWCLK is a clock signal. To the chip, it is an input and will always be an input. SWDIO is a data signal. It switches between the input state and the output state during data transmission, and the default is the input state.

Some LKS07x SWD pins also have GPIO function. The IO multiplexed by SWCLK is P2.14 and the IO multiplexed by SWDIO is P2.15. The precautions are as follows:

- The default state of GPIO multiplexing is disabled, IO are used as SWD. After the hard reset of the chip, the initial state of IOs are SWD. Both IOs of SWD are fixed pull-up inside the chip (the internal pull-up resistor of the chip is about 12K). Please pay attention to the initial IO voltage level if application has specific requirements.
- When GPIO multiplexing is enabled, tools such as KEIL cannot directly access the chip, i.e., the Debug and erase download functions cannot access the chip since SWD are now general GPIO. If the program needs to be downloaded again, there are two solutions.
  - Firstly, it is recommended to use Linko's dedicated offline downloader to erase. It is recommended to leave a certain margin before switching SWD to GPIO, such as about 100ms, to ensure that the offline downloader can erase the chip and prevent the deadlock. This margin is to ensure a successful offline downloader erasing. A greater margin means a greater probability of the successful one-time erasion.
  - Secondly, the application should have a GPIO multiplexing exit mechanism. For example, some other IO invert (usually input), indicates that the SWDIO is required externally, and the software needs to be reconfigured to disable the multiplexing. At this moment, the KEIL function can access the chip via SWD again.

In SSOP24L package and QFN5\*5 40L-0.75 package, SWDIO is directly bonded with P0.0 and P2.15, and the corresponding GPIO can be directly enabled. It is recommended that SWDCLK keep unchanged (constant 1 or constant 0) when multiplexing SWDIO

For LKS077E, SWDCLK is bonded with P2.6 and the corresponding GPIO can be directly enabled. If SWDIO and SWDCLK are multiplexed at the same time, considerations for SWDCLK multiplexing are as follows:

- The default state of GPIO multiplexing is disabled, IO are used as SWD. After the hard reset of the chip, the initial state of IOs are SWD. Both IOs of SWD are fixed pull-up inside the chip (the internal pull-up resistor of the chip is about 12K). Please pay attention to the initial IO voltage level if application has specific requirements.
- When GPIO multiplexing is enabled, tools such as KEIL cannot directly access the chip, i.e., the Debug and erase download functions cannot access the chip since SWD are now general GPIO. If the program needs to be downloaded again, there are two solutions.
  - Firstly, it is recommended to use Linko's dedicated offline downloader to erase. It is recommended to leave a certain margin before switching SWD to GPIO, such as about 100ms, to ensure that the offline downloader can erase the chip and prevent the deadlock. This margin is to



ensure a successful offline downloader erasing. A greater margin means a greater probability of the successful one-time erasion.

- Secondly, the application should have a GPIO multiplexing exit mechanism. For example, some other IO invert (usually input), indicates that the SWDIO is required externally, and the software needs to be reconfigured to disable the multiplexing. At this moment, the KEIL function can access the chip via SWD again.

When SWDCLK and SWDIO pins are used as GPIO, they should not act at the same time. That is, when SWDCLK multiplexing is enabled and changes, SWDIO can remain at level 0 (similar to time division multiplexing).

For RSTN signal, the default is for the external reset pin of LKS07x chip.

LKS07x allow users to multiplex RSTN as other IOs, and the multiplexed IO is P0.2. The precautions are as follows:

- The default state of reset IO multiplexing is disabled, and the software needs to write 1 to SYS\_RST\_CFG[5] to multiplex RSTN as GPIO. I.e., the initial state of P0[2] is RSTN. RSTN is provided with a pull-up resistor inside the chip (the internal pull-up resistor of the chip is about 300K). Attention shall be paid when the application has requirements for initial electric level.
- The default state of P0[2] is used as external reset, and the program can only be executed after the RSTN is released. The application needs to ensure that the RSTN has sufficient protection, such as the peripheral circuit with a pull-up resistor. It is better to add a capacitor.
- After RST IO multiplexing is enabled, the external reset is unavailable to the chip. If a hard reset is required, the reset source can only be power-down/watchdog reset.
- The multiplexing of RSTN does not affect the use of KEIL.

Bit [5] in the SYS \_ RST \_ CFG register controls the switch for multiplexing RSTN and P0.2.

## 26 Ordering Information

### Tray Package:

Package Type	Quantity per disc/tube	Quantity in box	Quantity in case
SOP16/ESOP16L	3000/ disc	6000PCS	48000PCS
SSOP24	4000/ disc	8000PCS	64000PCS
SSOP24	50/ pipe	10000PCS	4000/100000PCS
QFN 8*8	260/ disc	2600PCS	15600PCS
QFN 4*4/5*5/6*6	490/ disc	4900PCS	29400PCS
QFN 3*3	5000/ disc	5000PCS	40000PCS
LQFP48/TQFP48 0707	250/ disc	2500PCS	15000PCS
LQFP64 1010	160/ disc	1600PCS	9600PCS
LQFP100 1414	90/ disc	900PCS	5400PCS
TSSOP20/28	4000/ disc	8000PCS	64000PCS

### Reel Package:

Package Type		Quantity per disc/tube	Quantity per box	Quantity boxes per case	Quantity per case
Braid -13 inches	SOP/ESOP8	4000	8000	8	64000
Braid -13 inches	SOP/ESOP16	3000	6000	8	48000
Braid -13 inches	SSOP24	4000	8000	8	64000
Braid -13 inches	TSSOP20	4000	8000	8	64000
Braid -13 inches	D/QFN3*3	5000	10000	8	80000
Braid -13 inches	D/QFN4*4	5000	10000	8	80000
Braid -13 inches	D/QFN5*5	5000	10000	8	80000
Pipe	SOP16	50	10000	10	100000
Pipe	SOP14/SSOP24	50	10000	10	100000
Pipe	TSSOP24	54	6480	6	38880



## 27 Version history

Table27-1 Document version history

Time	Version No.	Description
2026.03.09	1.34	Revise the CMP trip voltage parameters
2026.01.27	1.33	Electrical Parameters – Other Models Omitted
2026.01.26	1.32	Add the configuration description block diagram for the DAC module.
2026.01.20	1.31	Add ADC configuration flowchart, and delete the description that the CAN requires an external crystal oscillator.
2026.01.12	1.30	Revise the pin description of KBT8
2026.01.08	1.29	Remove non-matching model types from the selection table.
2025.12.28	1.28	Revise the MCPWM module description to: Two chopper modules, with each group sharing one dead-time configuration.
2025.12.24	1.27	Retain only LQFP48 for the 07 series packaging.
2025.11.03	1.26	Revised OPA Module Common-Mode Level
2025.09.16	1.25	Add SPI module
2025.09.04	1.24	CBT8/C8T8 add LQFP48 package diagram and dimensions
2025.08.22	1.23	Update naming rules
2025.08.21	1.22	CBT8 and C8T8 packages changed to LQFP48
2025.08.14	1.21	CBT8 and C8T8 add LQFP package
2025.08.06	1.20	KBT8 Update Pin Information
2025.07.21	1.19	Delete the Flash section: erase/program one sector while accessing another
2025.04.02	1.18	Modify the pull-up resistor
2025.03.26	1.17	Add 32kb EEPROM, P0.9 connected to SCL, P0.10 connected to SDA
2025.01.02	1.16	Update the offset voltage of the CMP
2024.09.29	1.15	The belly Pad grounding of a QFN package is defined as Pin0
2024.08.28	1.14	Modify the mapping between MCPWM and GPIO of 072KBT8
2024.08.14	1.13	Add LKS32MC072KBT8
2024.08.04	1.12	Order package information updates to confirm package information by package type and package form
2024.03.12	1.11	Add LKS32MC073HBQ8
2023.12.20	1.1	Update 072 FLASH size
2023.11.20	1.09	Add description of OPA offset
2023.10.22	1.08	Modify the device selection table
2023.09.25	1.07	Update welding temperature, modify non-volatile memory Sector erase description
2023.08.23	1.06	Update 072/077 FLASH size
2023.07.27	1.05	Modify/updated a new model 07x 6N in the device selection table
2023.07.04	1.04	LKS32MC071C8T8 removes CAN function, modify the opa output signal range, power supply range, sleep power consumption and Vcm
2023.05.16	1.03	Add LKS32MC071C8T8

2023.05.07	1.02	Update the number of times the flash can be erased repeatedly
2023.04.07	1.01	Update package description
2023.03.16	1.0	Initial version



# Disclaimer

LKS and LKO are registered trademarks of Linko.

Linko tries its best to ensure the accuracy and reliability of this document, but reserves the right to change, correct, enhance, modify the product and/or document at any time without prior notice. Users can obtain the latest information before placing an order.

Customers should select the appropriate Linko product for their application needs and design, validate and test your application in detail to ensure that it meets the appropriate standards and any safety, security or other requirements. The customer is solely responsible for this.

Linko hereby acknowledges that no intellectual property licenses, express or implied, are granted to Linko or to third parties.

Resale of Linko products on terms other than those set forth herein shall void any warranty warranties made by Linko for such products.

Prohibited for military use or life care and maintenance systems.

For earlier versions, please refer to this document.

